

SciCan

BRAVO G4

Chamber Autoclave

Operator's Manual



- For US Customers Only -

1.	FOREWORD	1
1.1	Symbols used	1
1.2	Symbols on the device	1
1.3	Relevant standards	1
1.4	Intended use	2
1.5	General warnings	2
1.6	Residual risks	3
1.7	Information on mitigation of residual risks	3
1.8	Network and data security	5
2.	PACKAGE CONTENT	6
2.1	Dimension and weight	6
2.2	Description of the content	6
2.3	Product handling	7
2.4	Conditions for storage and transport	7
3.	GENERAL DESCRIPTION - PRODUCT PRESENTATION	8
3.1	General characteristics	8
3.2	Technical specifications	9
3.3	Safety devices	11
3.4	Water supply characteristics	12
3.5	Front	13
3.6	Rear	14
3.7	LCD icons	14
3.8	Example of working cycle	15
4.	SETTING UP THE DEVICE	16
4.1	Overall dimensions	16
4.2	Compartment dimensions for built-in installation	17
4.3	General precautions for installation	17
4.4	Power supply	18
4.5	Electrical connections	18
4.6	Direct connection to a centralized draining point	18
4.7	Anti-dust filter installation	19
5.	FIRST START-UP	20
5.1	Starting	20
5.2	Main menu	22
5.3	Filling demineralized / distilled water	22
6.	CONFIGURATION	23
6.1	Settings	23
7.	PREPARATION OF THE MATERIAL	30
7.1	Treating the material before sterilization	30
7.2	Arranging the load	31
7.3	Positioning and use of tray holder support	33
8.	STERILIZATION CYCLES	34
8.1	Extra drying	35
8.2	Delayed start	36
8.3	Execution of the cycle	37
8.4	Cycle outcome	37
8.5	Door opening at the end of the cycle	37
8.6	User-defined cycle	38
9.	MATERIAL STORAGE	39

Manufactured for :

SciCan Ltd.

A Coltene Group Company
1440 Don Mills Rd.,
Toronto, ON, M3B 3P9 / CANADA
T +1-416-445-1600
TF +1-800-667-7733
customerservice@scican.com

10.	TEST PROGRAMS	40
10.1	B&D cycle	40
10.2	Vacuum test cycle	41
10.3	Vacuum test + B&D cycle	41
10.4	H ₂ O test	42
10.5	Door opening	42
10.6	Manual interruption	43
11.	USED WATER DRAIN	44
12.	DATA MANAGEMENT & CONNECTIVITY	45
12.1	USB management	45
12.2	Wifi	47
12.3	Printers	49
12.4	Ethernet	50
12.5	G4 cloud	50
13.	APPENDIX – PROGRAMS	51
13.1	Summary table of 17 - 120 v cycles	52
13.2	Summary table of 17 - 240 v cycles	54
13.3	Summary table of 22 - 120 v cycles	56
13.4	Summary table of 22 - 240 v cycles	58
13.5	Sterilization program diagram	61
13.6	Diagrams of the test programmes	63
13.7	Examples of printed reports	64
14.	APPENDIX - MAINTENANCE	65
14.1	Regular maintenance programme	65
14.2	Scheduled maintenance messages	66
14.3	Description of maintenance interventions	67
14.4	Periodic sterilizer validation	71
14.5	Device useful life	71
14.6	Disposing the equipment when no longer used	71
15.	APPENDIX - GENERAL PROBLEMS	72
15.1	Troubleshooting	72
16.	APPENDIX – ALARMS	74
16.1	Alarm intervention	74
16.2	Alarm during a cycle	74
16.3	System reset	74
17.	ALARM CODES	75
17.1	Errors (category E)	75
17.2	Alarms (category A)	77
17.3	Hazards (category H)	80
17.4	System errors (category S)	81
17.5	Troubleshooting	82
18.	USER PIN RESET	90
19.	MANUAL DOOR OPENING	90
20.	APPENDIX - ACCESSORIES	92
21.	PRINTER CONNECTION	93
22.	APPENDIX - SPARE PARTS AND ACCESSORIES	93
23.	APPENDIX - TECHNICAL SERVICE	93
24.	APPENDIX - WARNINGS AND LOCAL REGULATIONS	93

1. FOREWORD

The instructions inform the user on how to properly operate the device. It is extremely important to read this manual carefully and thoroughly before using the device.

This publication must not be reproduced, copied or transferred in any manner (electronically, mechanically, via photocopies, translations or other means) without the prior written consent of the manufacturer.

The manufacturer has a company policy of continual development. Therefore, some of the instructions, specifications and figures given in this manual may slightly differ from the purchased product. The manufacturer reserves the right to make changes to this manual without giving prior notice.

The original text is in Italian; this is a translation from the original in Italian.

1.1 SYMBOLS USED

Type in Gray Box

Pay particular attention to the paragraphs marked in a gray box.



Type in Gray Box

Potential danger for people, environment and property.

Follow the procedures indicated in the manual to prevent potential damage to materials, devices and/or property.

1.2 SYMBOLS ON THE DEVICE



Potential danger due to high temperature.



Disposal in accordance with state/local regulation.

I/O

Switch ON / OFF.



Refer to the User Manual.



Fuses 2xT15A 250V.

1.3 RELEVANT STANDARDS

The product described in this manual is manufactured in accordance with safety standards and doesn't represent any danger for the operator if used according to the following instructions.

The product is **complying** with the following standards as applicable:

IEC 61010-1:2010 + A1:2016,	Safety requirements for electrical equipment for measurement, control, and laboratory use, Part 1: General requirements.
IEC 61010-2-040:2015,	Safety requirements for electrical equipment for measurement, control, and laboratory use, Part 2-040 Particular. requirements for sterilizers and washer-disinfectors used to treat medical materials.
IEC 61326-1:2012,	Electrical equipment for measurement, control and laboratory use – EMC requirements, Part 1: General requirements.
IEC 62304:2006 + A1:2015,	Medical device software - Software life-cycle processes.
ANSI/AAMI ST55:2016,	Table top steam sterilizers.
ASME Boiler and Pressure Vessel Code Section VIII, Division 1	

1.4 INTENDED USE

The product described in this manual is only intended for sterilization of reusable surgical instruments and materials.

DEVICE INTENDED FOR PROFESSIONAL USE



The use of the device is strictly reserved to qualified personnel. It must never be used or handled by untrained and/or unauthorized persons.

The device must not be used for the sterilization of fluids, liquids or pharmaceutical products.

The sterilizer is not a mobile or portable device.

1.4.1. IMPORTANT NOTES

Information contained in this manual is subject to change without notice.

The manufacturer is not responsible for direct, indirect or accidental damage resulting from or relating to the provision or use of this information.

This document may not be reproduced, adapted or translated, in part or in full, without the prior written permission of the manufacturer.

1.5 GENERAL WARNINGS

When using this product, **always** follow the instructions in the manual and never use it for anything other than its intended purpose.



The user is responsible for any legal requirements relating to the installation and use of the product. The manufacturer will not be held responsible for any breakage, malfunction, property damage or injury to people in the event that the product is not installed or used correctly, or proper maintenance is not carried out.

Please observe the following precautions in order to avoid injury or property damage:

- › Use **ONLY** demineralized / distilled water of high quality.



The use of water of inadequate quality can severely damage the device. See technical characteristics appendix in this regard.

- › **DO NOT** pour water or other fluids on the device.
- › **DO NOT** pour flammable substances on the device.
- › **DO NOT** use the system in the presence of flammable or explosive gases or vapours.
- › Before performing any maintenance or cleaning intervention, **ALWAYS DISCONNECT** power supply.



Whenever it is not possible to disconnect the power supply from the device, or if the external mains switch is distant or not visible to the maintenance technician, place a "work in progress" sign on the external mains switch after having turned it off.

- › Make sure the electrical system is grounded according to current laws and/or standards.
- › **DO NOT** remove any label or nameplate from the device; request new ones, if necessary.
- › Use **ONLY** original spare parts.



Failure to comply with the above exempts the manufacturer from all liability.



1.6 RESIDUAL RISKS

FOR THE USER

- › Contamination due to improper handling of the load.
- › Burn by contact with hot surfaces or fluids.

FOR THE PATIENT

- › Contamination due to unsterilized material caused by incorrect cleaning treatment before sterilization.
- › Contamination due to implementation of incorrect reprocessing procedures.
- › Contamination due to material unsuitable for sterilization or not compliant with instructions for use.
- › Contamination due to unsterilized material caused by incorrect final assessment of sterilization process.
- › Contamination due to missing or incorrect scheduled maintenance.
- › Contamination due to missing periodic validation.

1.7 INFORMATION ON MITIGATION OF RESIDUAL RISKS

FOR THE USER

Contamination due to improper handling of the load.

See chapter PREPARING THE MATERIAL.

Burn by contact with hot surfaces or fluids.

To extract the sterile material, once the sterilization process has been completed with saturated steam at 121°C / 250°F or 132°C / 270°F, proceed as follows:

- › Always wear PPE suitable for the handling of hot material and gloves of appropriate material and thickness.
- › Clean your gloved hands with a germicide detergent.
- › Always use the special tray extractor, supplied as standard, to extract the trays from the sterilization chamber.
- › Avoid any contact of trays and material with contaminated and/or non-heat-resistant surfaces.
- › Handle the sterile material making sure not to damage any packages, bags and containers serving as a barrier.

FOR THE PATIENT

Contamination due to unsterilized material caused by incorrect cleaning treatment before sterilization.

See chapter TREATING THE MATERIAL BEFORE STERILIZATION.

Contamination due to implementation of incorrect reprocessing procedures.

Make sure to use sterile material.

Contamination due to material unsuitable to sterilization or not compliant with instructions for use.

- › Check that the contaminated material is compatible with the selected sterilization process.
- › Immediately separate the materials to be sterilized from those that must not be subjected to such process or are not able to withstand it.

Contamination due to unsterilized material caused by incorrect final assessment of sterilization process.

The sterilization process electronic control system monitors the various phases, at the same time checking that the various parameters are respected; if any type of anomaly is encountered during the cycle, the program is immediately interrupted, generating an alarm identified by a code, with a relative message explaining the nature of the problem.

Furthermore, the sterilization process can be checked by means of:

CHEMICAL INDICATORS

That monitor the sterilization process by providing information, together with the control of physical and biological parameters, on the conditions occurred in the sterilization chamber during the process.

The final toning of the process indicator does not certify that the product is sterile but only that the device has been subjected to a sterilization process. If the toning does not occur, the operator in charge of releasing the sterile material, that must not be used, must put all actions to avoid the use of the treated material.

PHYSICAL INDICATORS

They include the reading of machine data and the execution of specific tests indicated during the validation phase for that specific cycle/load/autoclave. This control system can include:

- › Direct reading of the synoptic system (thermometer, pressure gauge, recorder, etc.).
- › Reading of prints/labels/files on which the data detected by the synoptic system are stored (parameters).
- › Execution of specific tests (Vacuum test, Bowie Dick test) according to local guidelines.

The operator in charge of the process certifies the validity of the load at the end of every cycle by means of the parametric release.

Contamination due to missing or incorrect scheduled maintenance.

The sterilizer, based on a preset programming, displays a warning message relating to the scheduled maintenance necessary to ensure the good operation of the device.

Contamination due to missing periodic validation.

See chapter PERIODIC STERILIZER VALIDATION.

1.8 NETWORK AND DATA SECURITY

The BRAVO Sterilizer includes an Ethernet connection and a Wi-Fi module that allows the sterilizer to connect to the local network and to useful services, including device troubleshooting and firmware updates.

The WiFi module supports IEEE 802.11 b,g,n with WEP, WPA, WPA2-PSK encryption standard in the 2.4 Ghz range.

Since the security of the connection depends on the configuration of the wireless infrastructure (router or access point), securing your Wi-Fi® connections is an important element of securing your data.

For maximum security, ensure your network is configured for WPA2 protection.

Avoid placing devices connected to your network in unsupervised public accessible places.

When using USB keys to download cycle data, check that the data has been copied in a supervised disk and that regular backup plans are executed.

Tips on securing a new network

- › Change the default network name (SSID) when installing new access points, routers, and gateways
- › Change the administrative credentials (username and password) that control settings of your Access Point / Router / Gateway
- › Enable WPA2 Personal (aka WPA2-PSK) with AES encryption on all client devices
- › Create a network passphrase that meets recommended guidelines
- › Check a firewall is enabled and correctly configured

Checking securing of an existing network

- › If your network is configured for an older generation of security (WEP or WPA) consider moving to WPA2 as soon as possible.
- › Select an effective network passphrase. In general, increasing length, complexity and randomness all improve the quality of a passphrase.
A passphrase should not contain a word found in a dictionary and should not include personal information (identification number, name, address, etc).
- › Periodically changing the passphrase on your network also increases security.
- › Check proper handling of user accesses and logging on your infrastructure (PCs, devices, etc).
- › Check a firewall is enabled and correctly configured.

2. PACKAGE CONTENT

Check the integrity of the product package upon receipt.

2.1 DIMENSION AND WEIGHT

Once the package is opened, check that:

- › The supply matches the specifications of the order (see the delivery note).
- › There is no visible damage to the product.

Dimensions and Weight	
Height	600 mm / 23.62 in
Width	600 mm / 23.62 in
Depth	700 mm / 27.56 in
Total weight	68 kg / 149.91 lbs

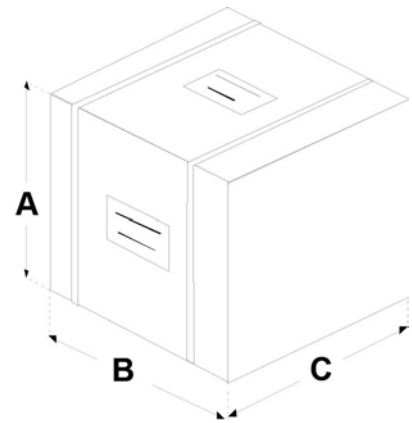

In case of wrong delivery, missing parts or any type of damage, immediately inform in detail the reseller and the carrier that made the delivery.

2.2 DESCRIPTION OF THE CONTENT

In addition to the sterilizer, the package contains:

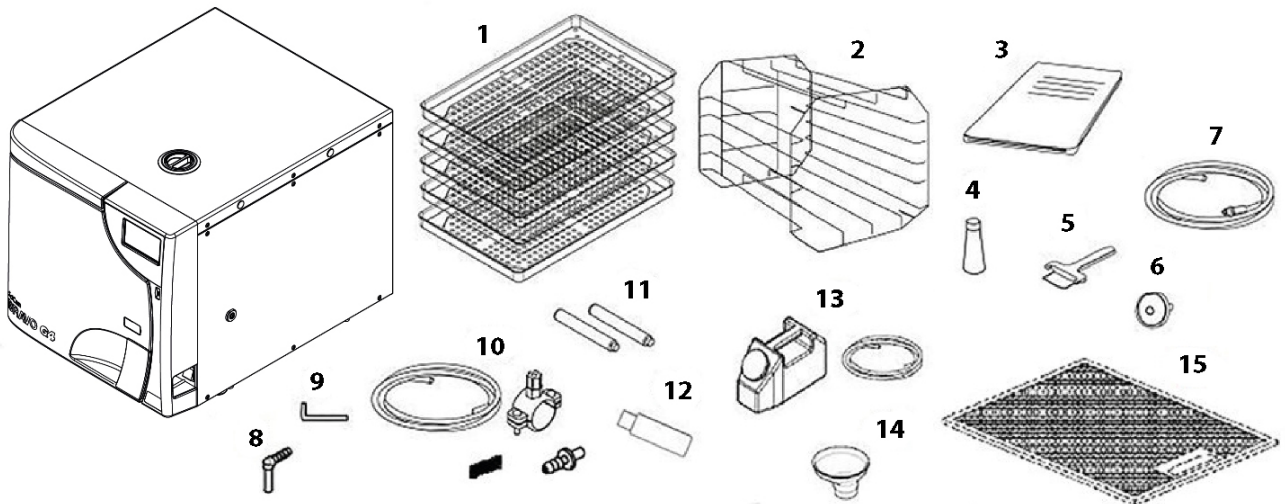

1. Instrument trays: 5 pcs
2. Tray holder support
3. Operator's documentation
4. Lubricant for door locking mechanism
5. Tray extractor
6. Additional bacteriological filter
7. Transparent silicone hose with quick coupling, for manual water drainage
8. Elbow hose connector
9. Allen wrench (for manual door unlocking)
10. Grey plastic tube for direct drainage, with fastening clamp, gasket, straight fitting
11. Rear spacers
12. USB key, containing user's manual
13. Bottle complete with silicone transparent tube and quick coupling, for manual water filling
14. Water filling funnel
15. Anti-dust filter

2.3 PRODUCT HANDLING

The packed product must be handled using, where possible, suitable mechanical means (lift truck, pallet truck, etc.) and following the indications on the package.

In case of manual handling, the product must be lifted by two people using the suitable available means.

Lift the product from the underneath on the sides.

Do not lift / hold the device by applying force to the door and its hinge.

Once the sterilizer has been removed from the package, it must be lifted by two people using the suitable available means and handled, if possible, using a truck or similar.



We recommend to transporting and storing the device at a temperature not below 5° C (41° F). Extended exposure to low temperatures may damage the product.

Store the original package and use it for any transport of the device. Using a different package may damage the product during shipping.



Before transport, leave the device turned off for about 30 minutes after the last program finishes and drain the filling and discharge tanks so that all the internal parts will have time to cool down.

2.4 CONDITIONS FOR STORAGE AND TRANSPORT

Temperature: between +5° C / +41° F and +70° C / +158° F

Humidity: between 20% and 80%

Pressure: between 50 and 110 kPa

3. GENERAL DESCRIPTION - PRODUCT PRESENTATION

3.1 GENERAL CHARACTERISTICS

The device is an electronic steam sterilizer, entirely operated by a micro-processor, with a large, moulded stainless steel sterilization chamber.

It is characterized by an advanced fractionated vacuum system for the complete removal of air, even from hollow, porous materials, and an effective final vacuum drying phase capable of eliminating all traces of humidity from any load.

The exclusive steam generation system, the effective hydraulic circuit and the electronic management (integrated by high-precision sensors) ensures high execution speed of process and an excellent stability of thermodynamic parameters.

Moreover, its Process Evaluation System constantly monitors all the machine's "vital" parameters in real-time, guaranteeing absolute safety and a perfect result.

The device offers users 6 sterilization programs (one of which completely programmable), all equipped with customizable, optimized drying for the effective sterilization of the various types of load (instruments and materials) used in a medical environment.

All the cycles can be selected on the clear LCD screen, which also allows extensive configuration of the device according to the user's needs.

Like in the best tradition, the new range of autoclaves feature the most complete and advanced safety systems available today, to ensure the user against any operation, electrical, mechanical, thermal or functional fault.

For the description of safety devices, refer to Technical Characteristics Appendix.

3.2 TECHNICAL SPECIFICATIONS

SUMMARY TABLE

Device	STEAM STERILIZER	
	BRAVO G4 17	BRAVO G4 22
Manufactured for	SciCan Ltd. A Coltene Group Company 1440 Don Mills Rd., Toronto, ON, Canada, M3B 3P9	
Input voltage	240 V~ 60 Hz 120 V~ 60 Hz	
Main fuses (6.3 x 32 mm) (0.25 x 1.26 in)	2x T15A 250V	
Electronic board fuses (5 x 20 mm) (0.20 x 0.79 in)	F1: T3.15A 250V (transformer primary 240 V~ 60 Hz / 120 V~ 60 Hz)	
Nominal power	2300 W (for 240 V~) 1440 W (for 120 V~)	
Insulation class	Class I	
Installation category	Cat. II	
Environmental operating conditions	Indoor use Temperature: +15°C (+59° F) ÷ +35°C (+95° F) Relative humidity: between 20% and 80% max. non-condensing Height: min -100 m (- 328 ft) / max 3000 m (9842 ft) (above sea lev.) Pollution degree max: 2	
A-weighted sound power level (ISO 3746)	< 67 db (A)	
External dimensions (HxWxD) (rear connections excluded)	456 x 480 x 600 mm 17.95 x 18.90 x 23.62 in	
Net weight: unladen	approx. 49.60 kg / 109.34	approx. 51.30 kg / 113.09
Net weight: unladen, with tray holder support and trays	approx. 51 kg / 112.44 lbs	approx. 53 kg / 116.84
Net weight: unladen, with tray holder support, trays and water at MAX. level	approx. 56.50 kg / 124.56	approx. 58.50 kg / 128.97
Sterilization chamber dimensions (D x D)	250 x 350 mm 9.84 x 13.78 in	250 x 450 mm 9.84 x 17.72 in
Sterilization chamber total volume	approx. 17 L (0.017 cu. m)	approx. 22 L (0.022 cu. m)
Sterilization chamber usable volume (with tray holder support inserted)	approx. 10 L (0.010 cu. m)	approx. 13 L (0.013 cu. m)
Sterilization chamber usable dimensions	17 L (1.38x1.55x2.97) dm / 6.4 cu. dm	22 L (1.38x1.55x3.97) dm / 8.5 cu. dm
Water tank capacity (filling)	approx. 5.5 L (water at MAX. level) approx. 1 L (water at MIN. level)	
Sterilization programs	5 standard programs + 1 program defined by the user	

Device	STEAM STERILIZER	
	BRAVO G4 17	BRAVO G4 22
Test programs	B&D Test	
	Vacuum Test	
	Vacuum Test + B&D Test	
Pre-heating time(from cold)	approx. 10 min.	
USB connection	Key capacity lower than or equal to 2GB: FAT formatting with 16K/sector	
	Keys capacity higher than 2GB: FAT32 formatting with 16K/sector	
Printer connection *	Serial RS232 (printer cable max. length 2.5 m – 8.20 ft)	
240 V 60 Hz Main power cord	Plug NEMA 6-15P 250V-15A	
	SJT 14 AWG / 3C 300V 60° C (140° F) Connector C19 acc. to IEC 60320	
120 V 60 Hz Main power cord	Plug NEMA 5-15 125 V-15A	
	Cable SJT 14 AWG / 3C STYLE 1015 60° C (140° F) Connector C19 acc. to IEC 60320	
Ethernet connection	RJ45 (max. cable length 29 m – 95.14 ft)	
WiFi	802.11 b/g/n (2.4 Ghz); WEP / WPA / WPA2-PSK encryption	
Bacteriological filter (filter element in PTFE)	Porosity: 0.027 microns	
	Connection: male connector 1/8" NPT	
Maximum flow of drained water	1 L/min.	
Temperature of drained water	50° C / 122° F	
Max. temperature of drained water	90° C / 194° F	
Total heat in Joule sent by the sterilizer to the surrounding air in 1 hour of continue operation	17 L = 3.6 MJ	22 L = 4 MJ
Manoeuvre/handling space	1 m x 1 m	
	3.28 x 3.28 ft	
Device	BRAVO G4 17	BRAVO G4 22
Working pressure	-0.8 ÷ 2.4 bar	-0.8 ÷ 2.4 bar
Safety device setting	2.4 bar	2.4 bar

* The optional external printers Ref. M7D200012 is compatible with the BRAVO G4.

Refer to the printer manual for printer startup and paper loading.

3.3 SAFETY DEVICES

The sterilizer is equipped with the following safety devices for which we provide a brief description of their function:

- › **Mains fuses** (see data in summary table)
Protection of the whole device against possible failures of heating elements.
Action: power supply interruption.
- › **Electronic circuit protection fuses** (see data in summary table)
Protection against possible failures of the primary circuit of the transformer and of low voltage users.
Action: interruption of one or more low voltage circuits.
- › **Thermal circuit-breakers on mains voltage windings**
Protection against possible overheating of pump motors and of transformer primary winding.
Action: temporary cut-off (until cooling) of the winding.
- › **Safety valve**
Protection against overpressure in the sterilization chamber.
Action: release of the steam and restoration of the safety pressure.
- › **Safety thermostat with steam generator manual reset**
Protection against steam generator overheating.
Action: cut-off of the electricity to the steam generator.
- › **Safety thermostat with chamber heating element manual reset**
Protection against overheating of the heating elements of the container under pressure.
Action: cut-off of the electricity to the chamber heating element.
- › **Door position safety microswitch**
Confirmation of the correct closing position of the door of the container under pressure.
Action: signalling of wrong door position.
- › **Motor-driven door lock mechanism with electromechanical protection (pressure switch)**
Protection against accidental opening of the door (even in a blackout).
Action: prevents accidental opening of the door during a program.
- › **Door locking mechanism safety microswitch**
Striker for the correct closing position of door locking system.
Action: signalling of failed or wrong operation of door locking mechanism.
- › **Self-levelling hydraulic system**
Plumbing system structure for the spontaneous levelling of the pressure in the case of a manual interruption of the cycle, alarm or blackout.
Action: automatic restoration of atmospheric pressure in the sterilization chamber.
- › **Integrated system for evaluating the sterilization process**
Continuous verification of the sterilization process parameters entirely managed by microprocessor.
Action: immediate interruption of the program (in case of malfunction) and generation of alarms.
- › **Sterilizer operation monitoring**
Real-time oversight of all significant parameters when the machine is powered.
Action: generation of alarm messages (in the case of anomaly) with possible interruption of the cycle.

3.4 WATER SUPPLY CHARACTERISTICS

Only use demineralized / distilled water having the following characteristics to supply the sterilizer.

Description	Values in the Water Supply	Values Inside Residual
Dry Condensate	< 10 mg/L	< 1 mg/L
Silicone Oxide SiO₂	< 1 mg/L	< 0.1 mg/L
Iron	< 0.2 mg/L	< 0.1 mg/L
Cadmium	< 0.005 mg/L	< 0.005 mg/L
Lead	< 0.05 mg/L	< 0.05 mg/L
Heavy Metal Residues (Iron, Cadmium and Lead Excluded)	< 0.1 mg/L	< 0.1 mg/L
Chlorides	< 2 mg/L	< 0.1 mg/L
Phosphates	< 0.5 mg/L	< 0.1 mg/L
Conductivity At 20° C / 68° F	< 15 µS/cm	< 3 µS/cm
pH Value	5 - 7	5 - 7
Aspect	colourless, transparent, without sediment	colourless, transparent, without sediment
Hardness	< 0.02 mmol/L	< 0.02 mmol/L

When buying demineralized / distilled water, make always sure that the quality and characteristics declared by the manufacturer are compatible with those specified in the table.



The use of water for steam generation with presence of contaminants with levels exceeding those indicated in the above table can greatly shorten sterilizer lifetime. This could also result in an increase of oxidation in the most sensitive materials as well as in an increase of limescale residues on generator, boiler, internal supports, trays and instruments.

3.5 FRONT

1. Model
2. Control panel and LCD screen
3. Door
4. Power switch
5. Anti-dust filter

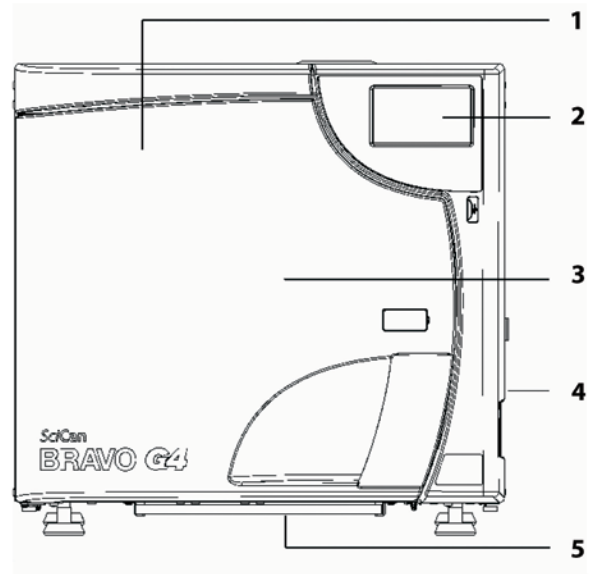

1. Sterilization chamber
2. Bacteriological filter
3. Door locking system
4. Water drainage filter
5. Front filling quick connector
6. Clean water reservoir drainage quick connector
7. Waste water drainage quick connector
8. Door
9. Steam diffuser
10. Door safety locking system

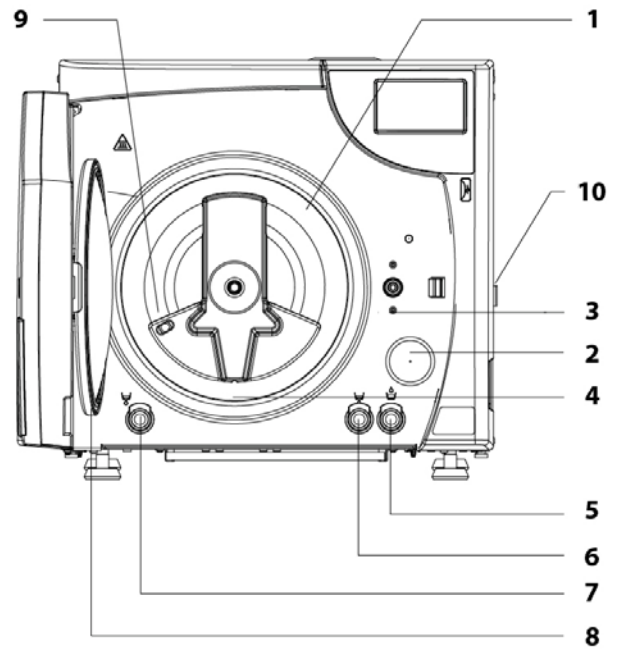

3.6 REAR

1. Fastening slots for rear spacers
2. Heat exchanger
3. Connection for direct water drainage
4. Connection for automatic demineralized / distilled water filling (only for H₂O AUX EV kit (AUX SV) and automatic filling accessory kit)
5. Data plate
SERIAL NUMBER LABEL (See image *)
6. Ethernet cable connection (max. length 29 m / 95,1444 ft)
7. Serial cable connection
8. Automatic filling electrical connection (only for H₂O AUX EV kit (AUX SV) and automatic filling accessory kit)
9. Network fuses
10. Power cable connection

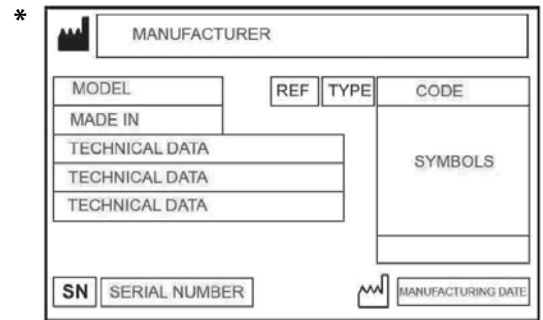
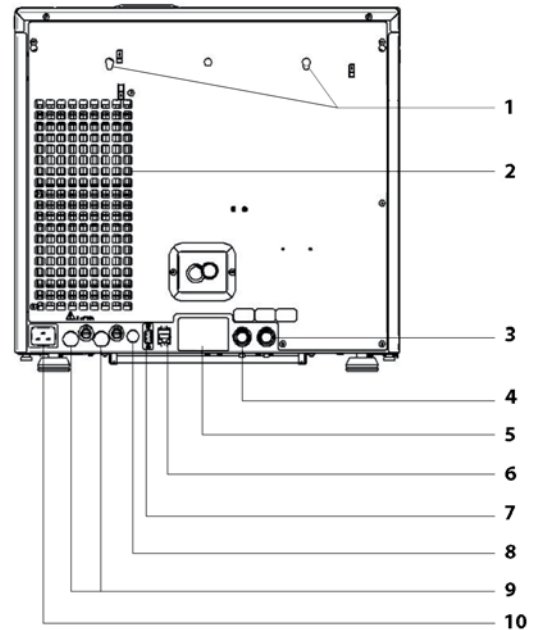

3.7 LCD ICONS

The screens in the following pictures may vary in shapes and colours, but their contents are the same as shown on the sterilizer display.

1. Selection for data management & connectivity
2. Selection of sterilization and test cycles
3. Time and date
4. Button for quick download of new cycles
5. System info selection
6. Door unlock
7. Selection of the sterilizer settings (Setup)

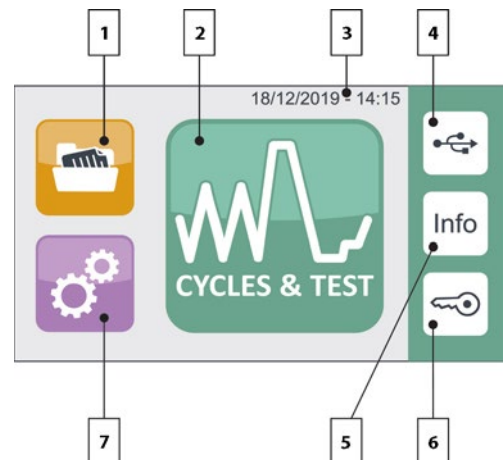

3.8 EXAMPLE OF WORKING CYCLE

The sterilization program can be effectively described as a succession of phases, each one with a very precise objective.

For example, a B CYCLE program: after loading the material in the chamber, closing the door, selecting the program and starting the cycle (after locking the door opening mechanism), the following sequence will occur (see the graph below):

1. Steam generator and sterilization chamber pre-heating.
2. Air removal and steam penetration in the material through a series of vacuum (extraction of air and fluid from the sterilization chamber) and pressure (injection of steam into the chamber) phases.
3. Pressure rises with the consequent increase in the temperature of the steam, until reaching the conditions required for sterilization (in the example, 132° C / 269.6° F).
4. Pressure and temperature stabilization.
5. Load sterilization for the required time (in the example, 4 minutes).
6. Sterilization chamber depressurization.
7. Vacuum drying phase.
8. Load ventilation, by means of sterile air.
9. Pressure levelling, bringing the sterilization chamber back to the atmospheric pressure level.

Having reached this last phase, you can unlock the door and remove the load from the sterilization chamber.

It should be emphasized that phases 1, 3, 4, 6 and 9 are identical in all cycles, with slight variations of duration that are solely dependent on the quantity and consistency of the load and the heating conditions of the sterilizer while phases 2, 5, 7 and 8 clearly vary their configuration and/or duration on the basis of the cycle selected (and, as a consequence, the type of load) and the choices made by the user.

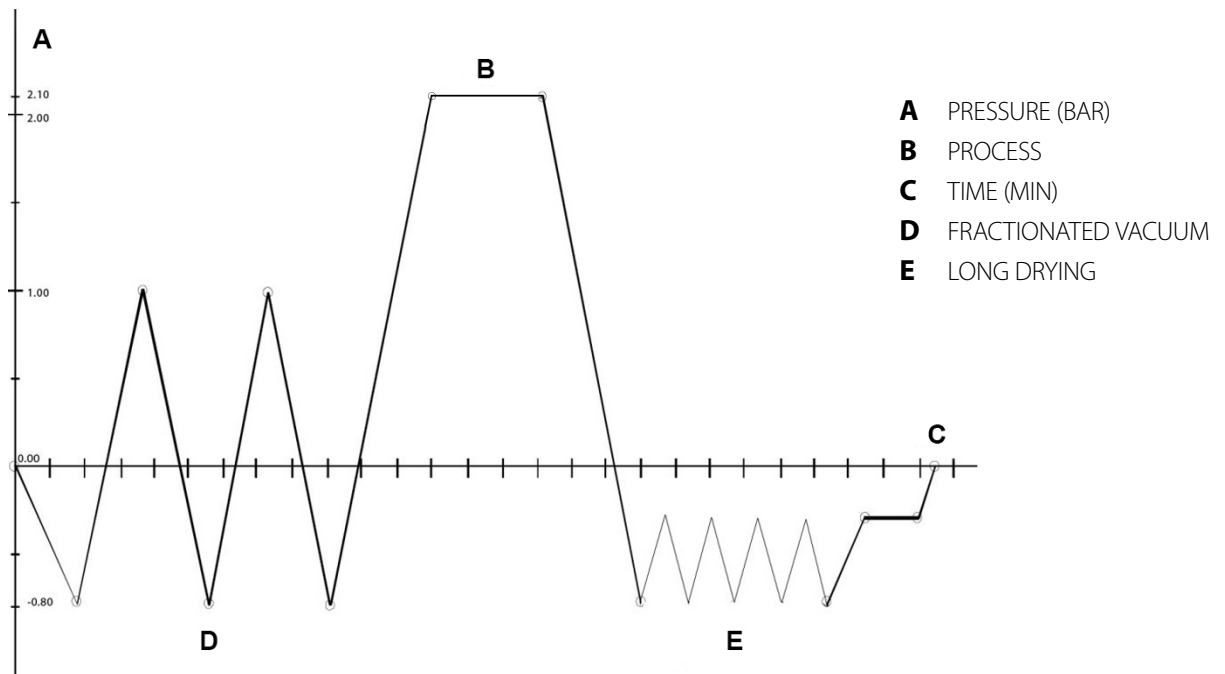

Please refer to the Programs Appendix for more details on programs.

4. SETTING UP THE DEVICE



The safety of every system which integrates the device is the responsibility of the system assembler.

The first and essential step for a proper operation of the sterilizer, its durability over time and complete use of its features, is a correct and careful commissioning. Moreover, this precaution will avoid the danger of physical injury or property damage, not to mention malfunctions and damage to the device.

Please **meticulously** follow the instructions contained hereafter in this chapter.

Technical Service department (see appendix) is available for further information.

The sterilizer is placed on the market only after having passed all the checks required. It does not require any additional calibration for commissioning.

Dimensions and Weight	17 L	22 L
A Height (total)	456 mm / 17.95 in	
B Width (total)	480 mm / 18.90 in	
Depth (excluding rear connections)	600 mm / 23.62 in	
C Note: the sterilizer can be positioned on a surface only 550 mm / 21.65 in deep	600 mm / 23.62 in	
Total weight (device only - no trays or holder, no water)	49.60 kg / 110.23 lbs	51.30 kg / 113.09 lbs
Total weight (max. load, including trays & holder, max. clean water)	62.50 kg / 137.78 lbs	66 kg / 145.50 lbs

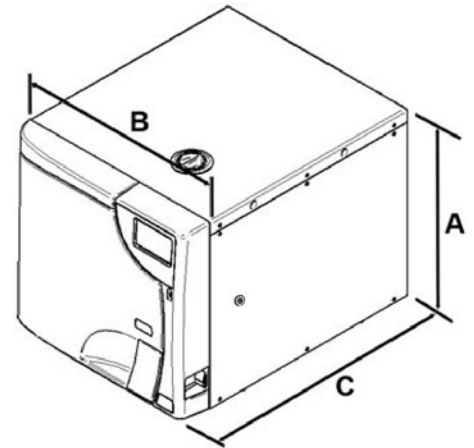

4.1 OVERALL DIMENSIONS

Centre distance and maximum overall dimensions of the sterilizer feet, with and without rear spacers (mm/in):

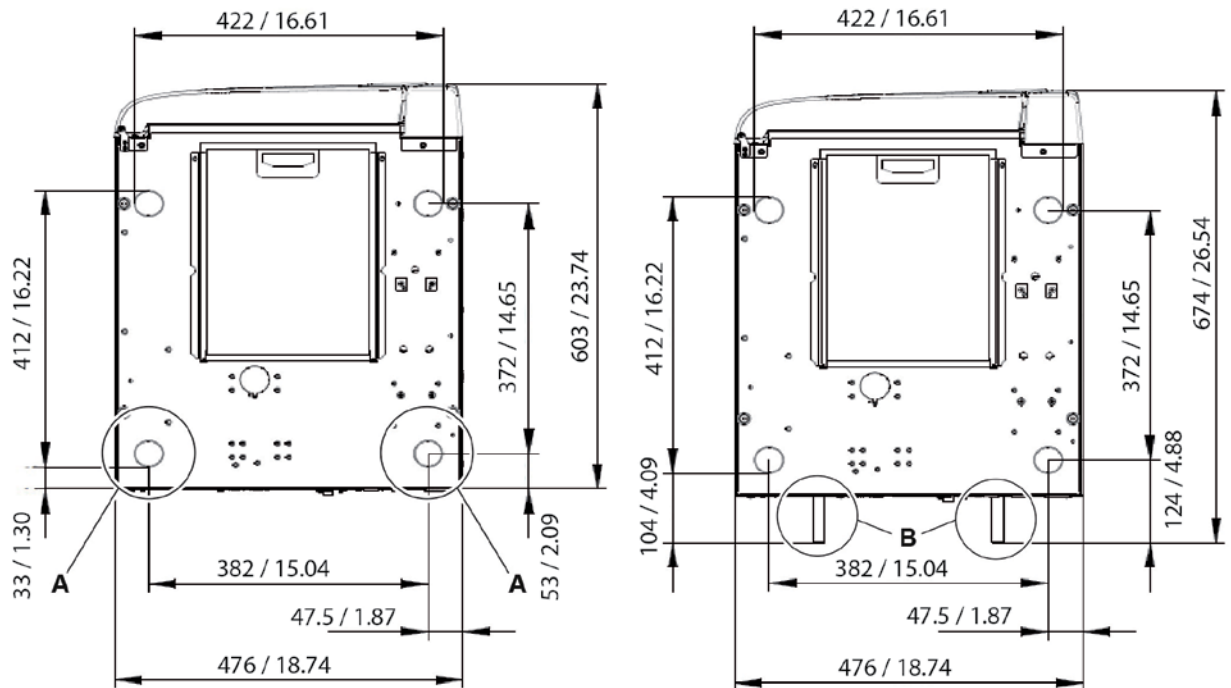

A Feet

B Rear spacers

4.2 COMPARTMENT DIMENSIONS FOR BUILT-IN INSTALLATION

When installing the sterilizer inside a cabinet, you must provide adequate space all around the device to provide effective ventilation as well as an opening in the back (D) - 180 sq.cm / 27,90 sq. inches - that, in addition to allowing the passage of the power cord, will also provide an adequate air flow and the optimum cooling of the heat exchanger.

Mount the rear spacers supplied to ensure that the sterilizer is placed at the correct distance from the wall.

The compartment where the sterilizer will be installed must have the following minimum dimensions:

Compartment Dimensions		Chamber Volume 17-22 L
A	Height	470 mm / 18.50 in
B	Width	520 mm / 20.47 in
C	Depth	670 mm / 26.38 in

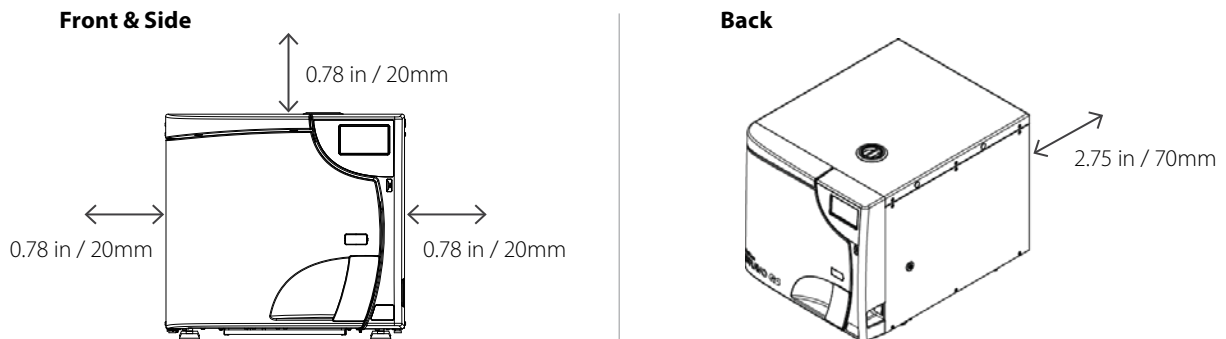

Compartment dimensions lower than those shown may compromise the correct circulation of air around the device and may not provide adequate cooling, with the consequent deterioration of performance and/or possible damage.

If the main switch is inaccessible when installed in the compartment, use an electric plug that incorporates an on/off switch. Do not remove the upper cover nor any other external part. The device must be completely installed in the compartment. Please refer to appendix "technical characteristics" in the User Manual for complete technical data.

4.3 GENERAL PRECAUTIONS FOR INSTALLATION

To ensure a correct operation of the device and/or avoid risky situations, respect the following warnings:

- › Install the sterilizer on a flat and perfectly horizontal surface.
- › Make sure that the support surface is strong enough to support the device weight (about 90 kg / 198.42 lbs, complete with water in hydrostatic test configuration).
- › Leave adequate space for ventilation all around the sterilizer, in particular in the rear area.
- › If the device is built into a cabinet, be sure to respect the warnings in the previous paragraph, avoiding any obstructions of the air intakes.
- › Do not install the sterilizer too close to tubs, sinks or similar places, avoiding contact with water or liquids. This could cause short circuits and/or potentially dangerous situations for the operator.
- › Do not install the sterilizer in excessively humid or poorly ventilated environments.
- › Do not install the machine in environments with flammable and/or explosive gasses or vapours.
- › Install the device so that the supply cable is not bent or squeezed.
- › Supply cable must freely run all the way to the electrical outlet.
- › Install the device so that any external filling/drainage tubes are not bent or squeezed.

4.4 POWER SUPPLY

- › The electrical system to which the sterilizer will be connected must match the electrical characteristics of the device.
- › Plate data are shown in the **TECHNICAL CHARACTERISTICS** table in the User Manual and on the back of the machine.

4.5 ELECTRICAL CONNECTIONS

This information is shown on the **back of the machine**.

The sterilizer must be connected to a socket of the electric system having adequate capacity for the device and properly grounded, in accordance with laws and/or regulations in force.



The manufacturer is not responsible for any damage caused by the installation of the sterilizer with unsuited and/or not properly grounded electric systems.

Always connect the power cord directly to the power outlet. Do not use extensions, adapters or other accessories.

4.6 DIRECT CONNECTION TO A CENTRALIZED DRAINING POINT

- › Remove the cap holding clip and the cap on the rear of the autoclave.
- › Fit the plastic tube on the elbow union (supplied).
- › Fit the union and then refit the clip.
- › Fasten the clamp (supplied) to the drain siphon.
- › Cut the tube to the right length and insert its free end into the centralized draining point union locking it with the dedicated ring nut.

Make sure that the tube is not bent, crushed or obstructed in any way.

The following diagram provides an arrangement of the components:

1. At the centralized draining point
2. Resting surface
3. Clamp
4. Drain siphon

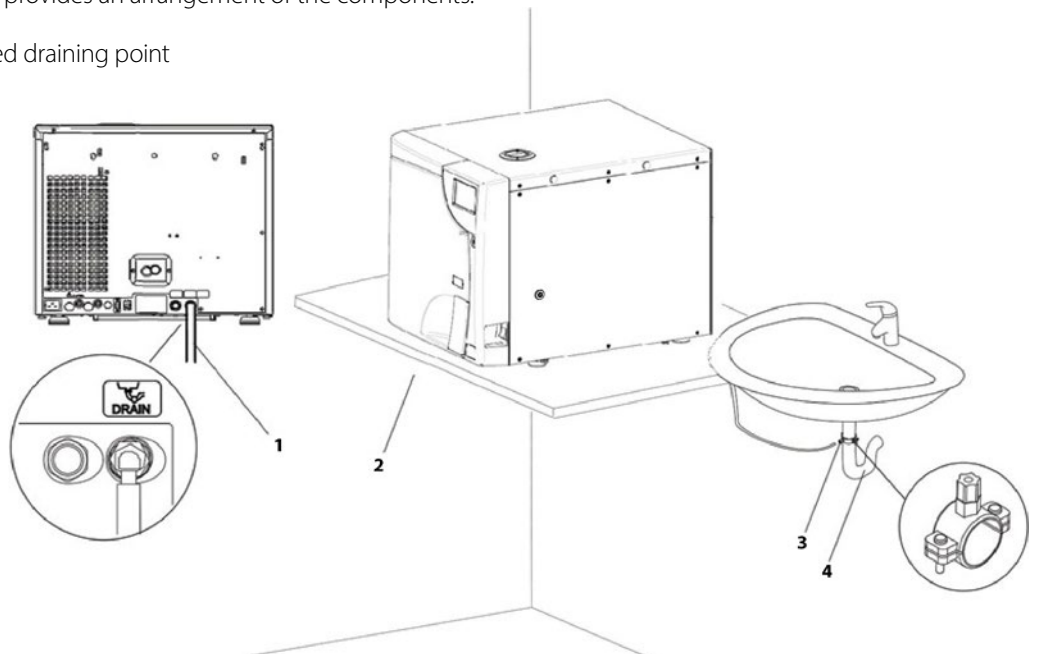

The position of the union of the centralized draining point must be lower than the resting surface of the sterilizer. Otherwise, the tank may not be emptied correctly.

If an automatic filling system (external pump or H2O AUX EV kit (AUX SV) is connected the use of the direct drain connection is required.

In case of fault or failure, this system allows any excess water produced by the automatic filling system to flow into the centralized draining point, thus preventing flooding.

4.7 ANTI-DUST FILTER INSTALLATION

Complete the autoclave positioning and install the anti-dust filter (**A**) by inserting it into the guides in the lower part of the device. Insert the filter until it is flush with the front of the unit and cannot be pushed further back.

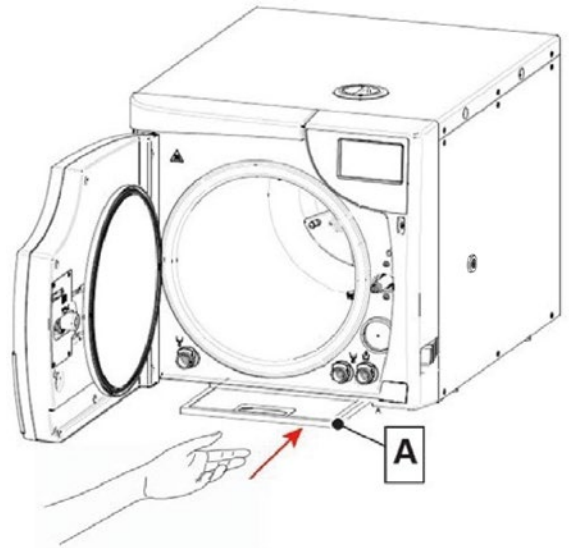

5. FIRST START-UP

The time required to start the sterilizer is approximately 30 seconds.

5.1 STARTING

Once the sterilizer has been correctly installed, turn it on with the main switch on the right-hand side of the machine.



Do not turn on the sterilizer if USB key is inserted. The unit scans for new software updates anytime a USB key is inserted and the machine is turned on. Only insert the USB key when you need to download cycle reports and when performing software updates

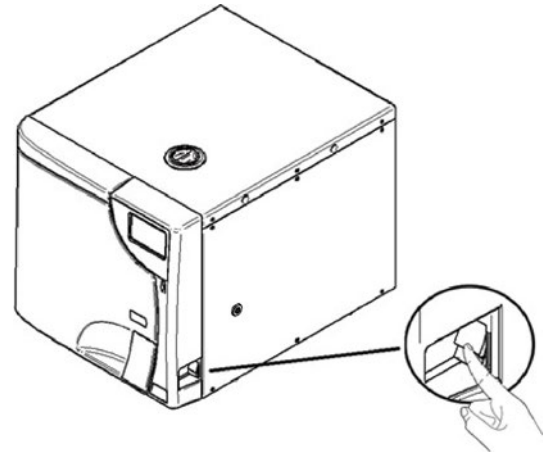

Step 1 – LANGUAGE setting

When the device is first turned on, the display shows the selection of LANGUAGE, DATE and TIME settings.

- › Select the field with ▲▼ and confirm using ENTER.
- › Use buttons ▲▼ to adjust the values.
- › Confirm using ENTER and adjust the other fields.

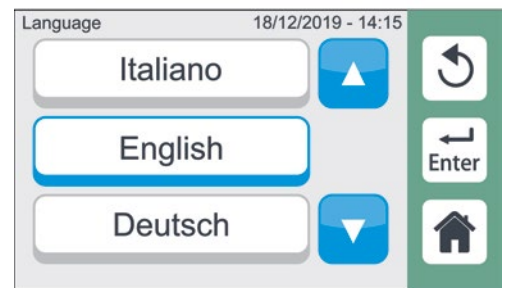

Step 2 – DATE setting



Step 3 – TIME setting

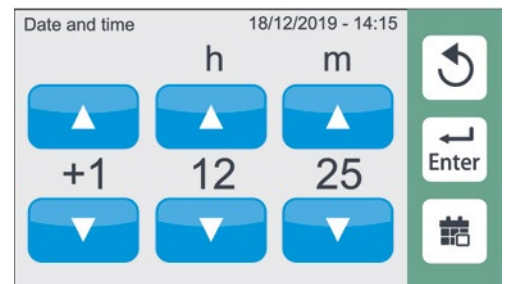

Step 4 - PREHEATING setting

Once LANGUAGE, DATE and TIME have been set, the PREHEATING screen appears.

See User Manual, paragraph **SETTINGS** section **PREHEATING**, to set the relevant parameters.

If the device is already connected to Ethernet and IP address is acquired, the First Start Up procedure will proceed to Step 8.

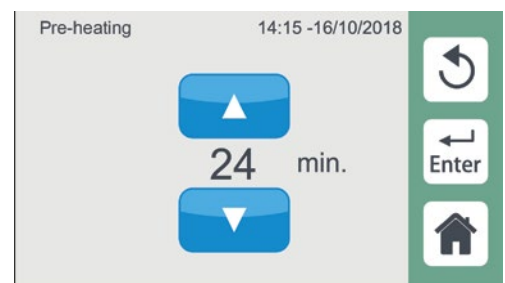

Step 5 - WiFi networks research

The device automatically searches for WiFi networks (max. 60 s).

If the device has an Ethernet connection but IP address not acquired, refer to Step 9 to complete the setup steps for connecting the device to Ethernet.



Step 6 - WiFi networks selection

Select and confirm.

If connecting the unit to WiFi at a later date, use the SKIP button to move to the next startup step.

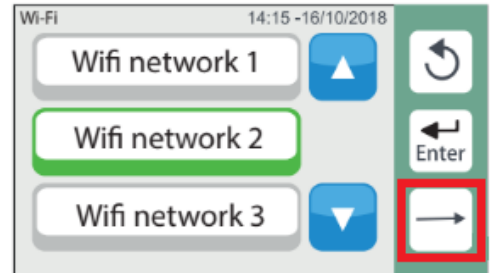

Step 7 - WiFi networks access

Insert the WiFi network access password and press ENTER to confirm.



Step 8 - CLOUD connection

Then the cloud connection page is displayed. Refer to G4 Cloud paragraph (12.5 in the User Manual).

Complete the online access activation by visiting www.scican.com/online-access/ and enter the activation code, or by scanning the QR code. Once finished, press "Home" to complete the first start procedure. The G4 Cloud Online Access Activation screen can be displayed at any time by clicking the Cloud icon.



Step 9 - ETHERNET connection

Refer to this step when connecting the unit to Ethernet and the IP address is not automatically acquired.

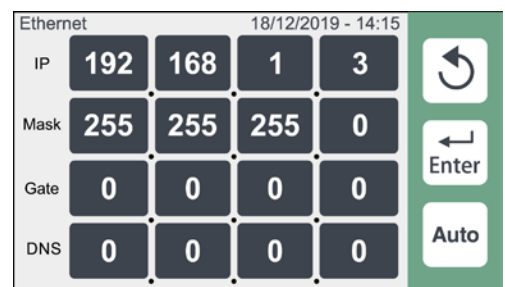

BRAVO G4's WiFi-enabled G4 technology allows connection and access to cycle data from any computer or smart device with browser capabilities, allowing staff to focus on the most important thing in a dental practice, the patients. Maintenance reminders, instructions and software updates keep your BRAVO G4 in good working order. Should your unit experience an error, G4 technology can connect your unit to specialized technicians who can provide remote support that can minimise unnecessary downtime.

5.2 MAIN MENU

At the end of the starting procedure the main menu is displayed on the side.

The sterilizer waits for the program selection (see "Program selection" Chapter in the User Manual).



5.3 FILLING DEMINERALIZED / DISTILLED WATER

Only use demineralized / distilled water having the following characteristics to supply the sterilizer.

Description	Values in the Water Supply	Values Inside Residual
DRY CONDENSATE	< 10 mg/L	< 1 mg/L
SILICONE OXIDE SiO₂	< 1 mg/L	< 0.1 mg/L
IRON	< 0.2 mg/L l	< 0.1 mg/L
CADMIUM	< 0.005 mg/L	< 0.005 mg/L
LEAD	< 0.05 mg/L	< 0.05 mg/L
HEAVY METAL RESIDUES (iron, cadmium and lead excluded)	< 0.1 mg/L	< 0.1 mg/L
CHLORIDES	< 2 mg/L	< 0.1 mg/L
PHOSPHATES	< 0.5 mg/L	< 0.1 mg/L
CONDUCTIVITY AT 20° C / 68° F	< 15 µS/cm	< 3 µS/cm
pH VALUE	5 - 7	5 - 7
ASPECT	colourless, transparent, without sediment	colourless, transparent, without sediment
HARDNESS	< 0.02 mmol/L	< 0.02 mmol/L

MANUAL FILLING

1. When filling the sterilizer for the first time during installation, fill the reservoir until you hear the audible beep and the LCD displays the message that Max Water Level has been reached.
2. After running cycles, if the LCD screen displays a Water Level Low warning, fill the reservoir until you hear the audible beep and the LCD displays the message that Max Water Level has been reached.

Remove the cap from the top cover. Pour in water taking care not to exceed the maximum level indicated inside the tank (MAX.). Put the cap back in the top cover.

Pay attention not to spill water on the machine; if water is spilled, promptly dry.

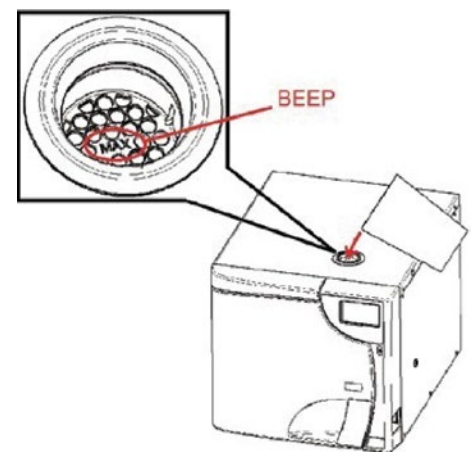

The tank must be filled before the cycle starts or after its completion. Do not open the tank doors during the cycle execution in order to prevent hot water leaks.

AUTOMATIC FILLING

For a listing of the automatic filling accessories available for the BRAVO G4, refer to the "ACCESSORIES" appendix in the User Manual.

6. CONFIGURATION

The sterilizers offer a wide range of customizable options. The user can thus configure the device according to their own needs, adapting the performance based on, for example, the type of activity carried out, the type of material to be sterilized and the frequency of use.

The CONFIGURATION menu offers the user a wide possibility to customize various device functions, by means of a user-friendly interface

Use the configuration program whenever necessary.

A correct customization of the device provides the best performance.

The Technical Service department (see appendix) is available to help users by providing suggestions or advices on the best way to use the options in the configuration program.

6.1 SETTINGS

To enter the configuration program, select the icon shown on the side.



LANGUAGE

Select the LANGUAGE option.



Select the desired language by scrolling the list using the arrows (▲▼) and confirm by pressing ENTER.

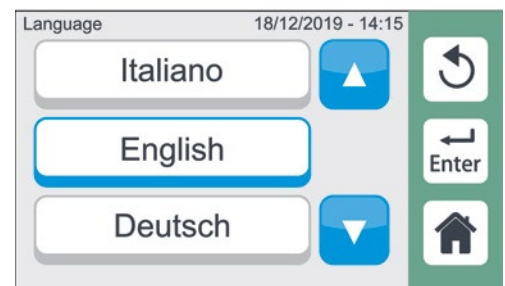

DATE AND TIME

Select DATE AND TIME option.

Select the field to be modified using the arrows and confirm by pressing ENTER.

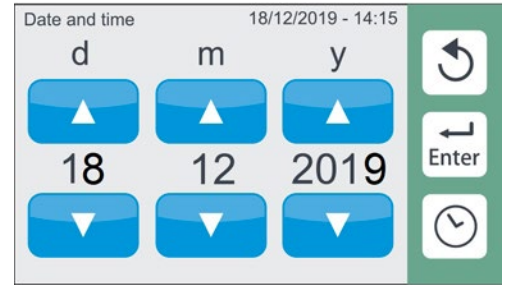
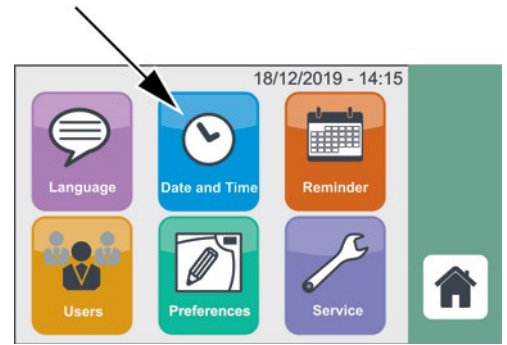

REMINDER

This function allows the user to set a specific interval for the display of a message recalling the execution of the relative test.

Select the REMINDER option.

Select if and when the Test reminders (Vacuum - B&D - Vacuum + B&D) should be enabled, using the available options.

Once the fields have been set, confirm by pressing ENTER. Reminders activate at 8 a.m. of the selected day or upon switching ON the unit (if it occurs after 8 a.m.).

The user can choose between:

- › Starting the test
- › Postponing the test (the reminder appears again the next day)
- › Ignoring the test (the reminder appears again at the next interval)

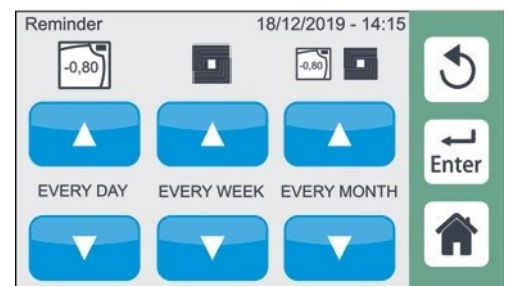
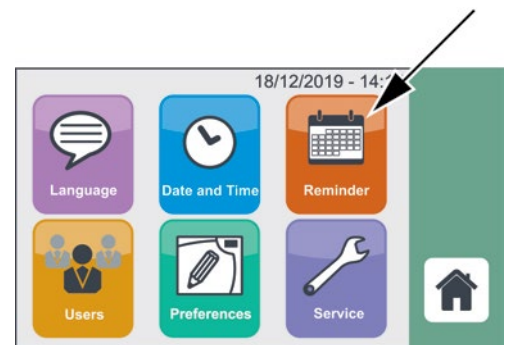

USERS

The users list can be edited with 30 users max.
Press USERS button to enter the menu.



When using the device for the first time create the ADMIN user (identified by *) following the steps outlined below. Fill in the fields inserting ADMIN user name and PIN. Press ENTER to confirm.

The first user entered is given administrator rights.

If the user enters the pin incorrectly 3 times, it is necessary to use the unlocking procedure described in APPENDIX - USER PIN RESET.

After you have entered the PIN, you can access the reserved administrator menu.

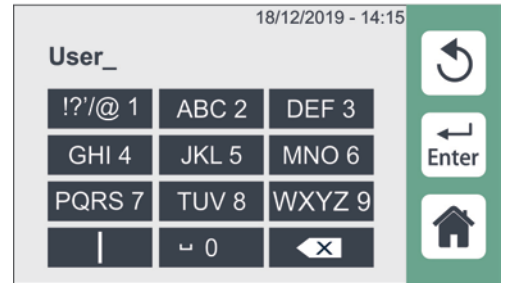

The ADMIN user can decide whether the sterilizer will ask for the generic user PIN at the cycle start (PIN Start) and/or at the end of the cycle (PIN End).

It is possible to activate either one of the two options or both.

By activating "PIN Start" the system requests the user to enter the PIN when the sterilization cycle starts.

By activating "PIN End" the system requires the user to enter the PIN at the end of the cycle before unlocking the door.

If PIN request is set at cycle start, press START to select the user and the relevant PIN.

Once the PIN is confirmed, the cycle starts automatically.

To create a new user, press the "+ User" button.

Fill in the fields inserting user name and PIN.

Press ENTER to confirm.



USERS LIST

Press USERS button to enter the menu.



Select the desired user.

You will access the screen containing the data of the selected user.

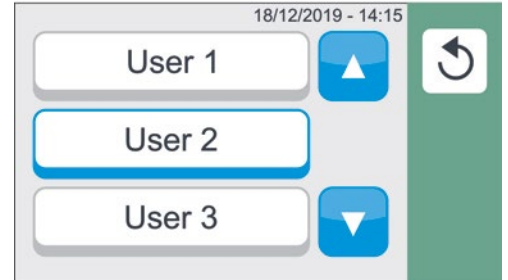

Once entered, a generic user can see only a summary of their data, or change their PIN (see entering PIN - the following is requested in sequence: current PIN, new PIN, new PIN confirmation).



The ADMIN can instead:

- › Give a generic user administration rights.
- › Delete the user (a pop-up will be displayed to confirm the deletion).
- › View Info on users. Select the cycles that the selected user is enabled to perform by pressing the related icons.

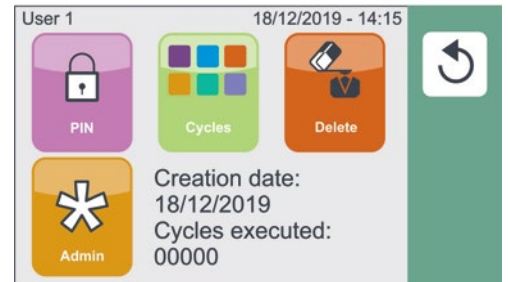

PREFERENCES

Press PREFERENCES button to enter the menu and set:

- › Units of Measurement
- › Display
- › Water Filling
- › Preheating



UNIT OF MEASUREMENT

Press the MEASUREMENTS icon to set the desired units of measurement (temperature, pressure), the time (12 or 24 hours) and the date format using the cursors shown in the figure.

Press ENTER to confirm the settings.



DISPLAY

Press the DISPLAY icon to select the screen settings.

The two cursors respectively adjust:

- › Screen Saver activation time-out
- › Screen brightness

Press ENTER to confirm the settings.

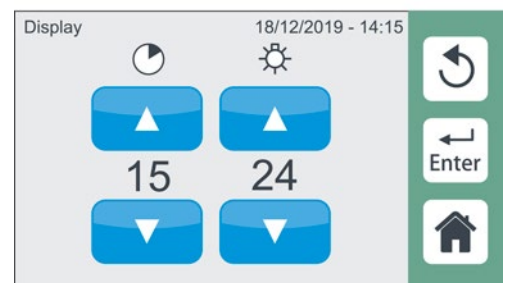
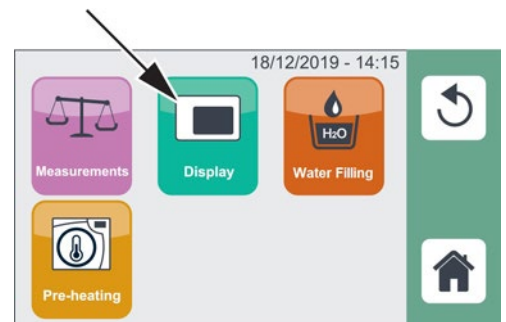

WATER FILLING

Press the WATER FILLING icon to choose the type of water filling.

Available options include:

- › Manual filling
- › External pump, automatic filling kit
- › H2O AUX EV kit (AUX SV)

The device should be turned on when connecting the water system. The unit's factory default fill setting is set to manual. When you plug one of the external automatic water filling devices into the rear port, the LCD will automatically display the water filling option screen so you can select the appropriate device.

If connecting the filling system when the sterilizer is off, access the menu via the configuration program and manually select the correct option.

This menu can also be used to temporarily deactivate the automatic filling system (filters exhausted, fault, etc.) and go to manual tank filling, keeping the automatic filling system connected.



PREHEATING

Select the PREHEAT icon to activate PREHEATING in the sterilization chamber.

The preheating max temperature settings are:

50°C/122°F with door open

100°C/212°F with door closed

Keep the door closed when not running the sterilization cycle to ensure the preheating achieves the max temperature level.

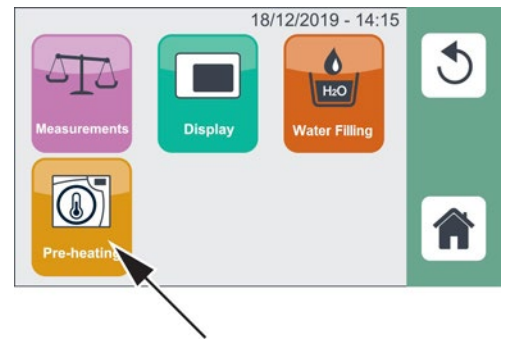

Use the arrows to scroll the PREHEATING available values:

- › **OFF**
- › **Minutes**
- › **Schedule**

The current selection is shown inside the blue box.

Confirm by pressing ENTER.

The preheating menu is displayed when the sterilizer is started for the first time, after selecting the language and date/time options. The preheating is OFF by factory default.

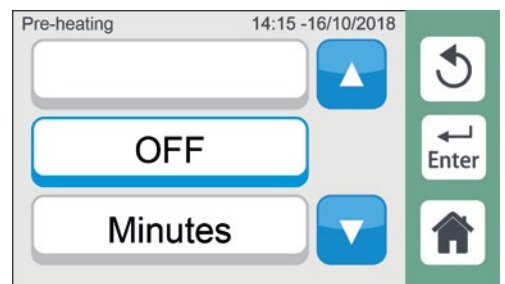

Select **Minutes**, confirm by pressing ENTER.

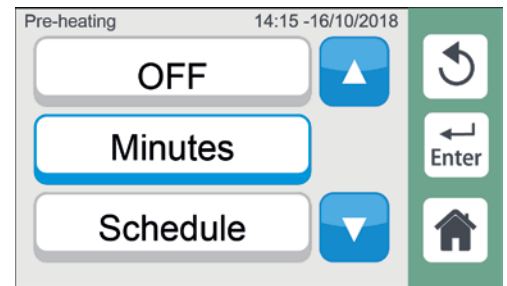

The arrows allow setting the maximum operating time, after which the PREHEATING is disabled.

Confirm by pressing ENTER.

The user can set preheating time up to 720 minutes (12 hours).

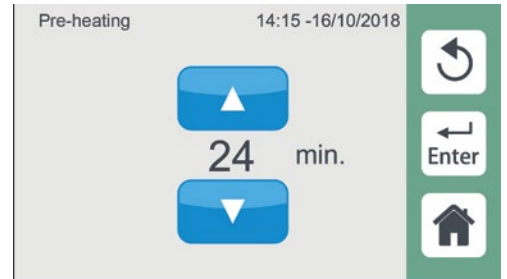

Select **Schedule**, confirm by pressing ENTER

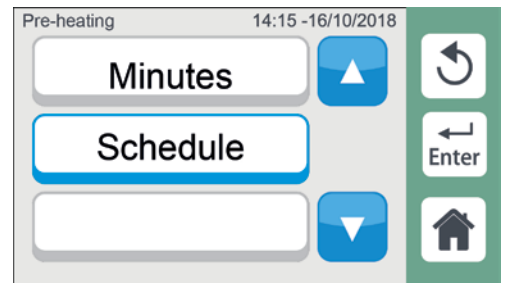

Set the PREHEATING power on time by means of START counters.

Set the PREHEATING power off time by means of END counters.

Confirm by pressing ENTER.



SERVICE

This menu is intended for the Technical Service department.

It can be used only by an authorized technician.



7. PREPARATION OF THE MATERIAL



Always use personal protective equipment.



Clean and rinse all instruments before loading them into the sterilizer. Disinfectant residues and solid debris may inhibit sterilization and damage the instruments and the BRAVO G4.

Unwrapped instruments, once exposed to ambient or external conditions, cannot be maintained in a sterile state. If sterile storage is desired, wrap the instruments to be sterilized according to the instrument manufacturer's instructions, select the appropriate wrapped cycle and allow it to run to completion.

To promote drying and enable effective sterilization, wrapped or pouched instruments must not touch each other.

SciCan recommends the final user carefully choose the most appropriate sterilization cycle according to the recommendations of their leading infection control authorities and local regulatory guidelines / recommendations.

User should use only sterilization wraps that have been cleared for their market. For U.S. customers, use only sterilization wraps that have been cleared by FDA for the sterilization program chosen.

7.1 TREATING THE MATERIAL BEFORE STERILIZATION

An effective cleaning consists of the following:

1. Separate metal instruments by type of material (carbon steel, stainless steel, brass, aluminium, chromium, etc.), to avoid electrolytic oxidation-reduction.



Solutions containing phenols or quaternary ammonia compounds can cause corrosion on instruments and on the metal parts of the ultrasonic device. Follow instrument IFU for effective cleaning.

2. If using an ultrasonic cleaner, ensure instruments are thoroughly rinsed and dried.
3. If using an automated washer, verify the dry cycle of the automated washer was completed.

For handpieces (turbines, contra-angles, etc), in addition to the above listed procedure, follow the Manufacturer instructions.



Consult the instructions provided by the manufacturer on the instrument/material to be sterilized before placing into the autoclave.

As regards textile materials (porous), such as lab coats, napkins, caps and other, carefully wash and dry them before treating them in the autoclave.

Do not use detergents with a high content of chlorine and/or phosphates. Do not bleach with chlorine-based products. These substances can damage the tray supports, trays and any metal instruments that may be present in the sterilization chamber.

7.2 ARRANGING THE LOAD



Always use personal protective equipment.



To get the best effectiveness of the sterilization process and preserve the material over time, increasing its useful life, follow the instructions below.

General notes for the positioning on trays:

- › When arranging unwrapped instruments made with different metals (stainless steel, hardened steel, aluminum, etc.) use different trays (whenever possible).
- › In case of instruments not made of stainless steel, put a sterilization paper napkin or a muslin cloth between instrument and tray, avoiding direct contact between the two different materials.
- › In any case, arrange the objects sufficiently spaced from each other, so that they can remain in such position for the whole sterilization cycle.
- › Make sure that all instruments are sterilized in an open position.
- › Position cutting instruments, (scissors, scalpels, etc.) so they can not come into contact with each other during sterilization; if necessary, use a cotton cloth or a gauze to isolate and protect them.
- › Arrange recipients (glasses, cups, test tubes, etc.) resting on their side, or upended, thus avoiding pooling water.
- › Do not load trays beyond the limit indicated (see Appendix); for the user defined cycle, the maximum load depends on the type of load inserted (e.g., "unwrapped", "solid", etc.) and on the parameters set by the user for that cycle. According to these aspects, refer to the loads of the cycles with fixed parameters.
- › Do not stack trays one on top of the other and do not put them in direct contact with the walls of the sterilization chamber.
- › Always use the supplied tray support.
- › To insert and remove trays from the sterilization chamber, always use the special supplied extractor.

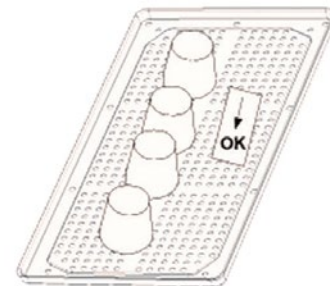

Use chemical process monitors suitable for steam autoclaves/sterilizers at the indicated cycle temperatures and times in or on each package or load being sterilized.

Only use FDA-cleared chemical and biological indicators. They should be designed for the particular sterilization cycle temperature and exposure time being monitored.

Notes for packages:

- › Arrange packages next to each other, duly spaced and not stacked, avoiding their contact with chamber walls.
- › Should it be necessary to wrap special objects, always use a suitable porous material (sterilization paper, muslin napkins, etc.), closing the package with adhesive tape suitable for autoclave.

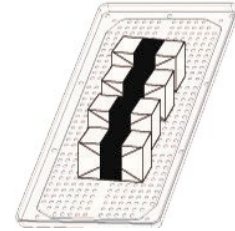

Notes for packed material:

- › Individually pack the instruments or, in case more than one instrument is placed inside the same pouch, make sure they are made of the same metal.
- › Do not use metal staples, needles or the like, as sterility could be affected.
- › Position pouches in such a way to leave the paper side up and the plastic side down (tray side).
- › Never stack pouches one on top of the other.



**Always pack instruments if they are going to be stored.
Refer also to the indications given in chapter “Sterilized Material Storage”.**

Program selection is an essential operation for the correct performance of the sterilization process.

Since all instruments or material in general have a different structure, consistency and properties, **the most suitable program must be identified**, both to preserve the physical characteristics (avoiding or, in any case, limiting its alterations) and to ensure the best effectiveness of the sterilization process.

A guide for the selection of the correct program based on the load is present inside **Programs Appendix**.

7.3 POSITIONING AND USE OF TRAY HOLDER SUPPORT

1. Tray holder support can be used in "tray" version (5 compartments).

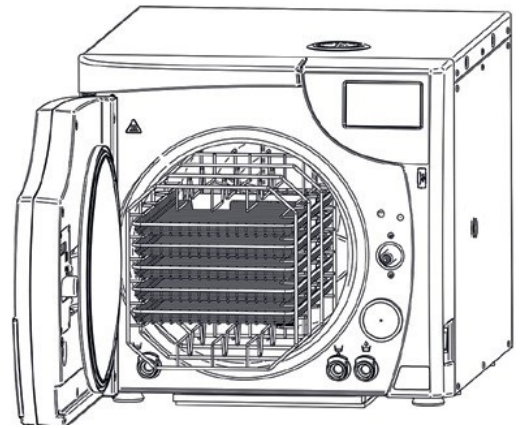

2. The tray holder support can be rotated to house special "cassettes" (3 compartments) in a 45° tilted position.

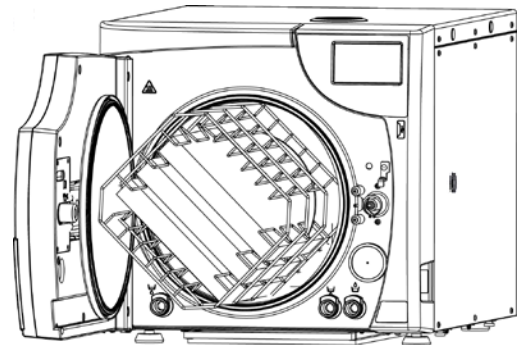

3. The tray holder support can be rotated to house special "cassettes" (3 compartments) in a vertical position.

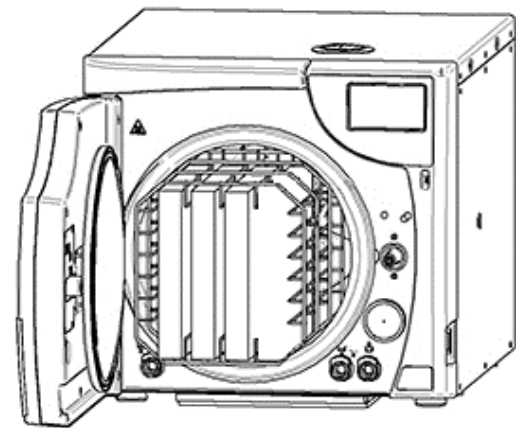

4. The tray holder support can be rotated to house special "cassettes" (3 compartments) in a horizontal position.

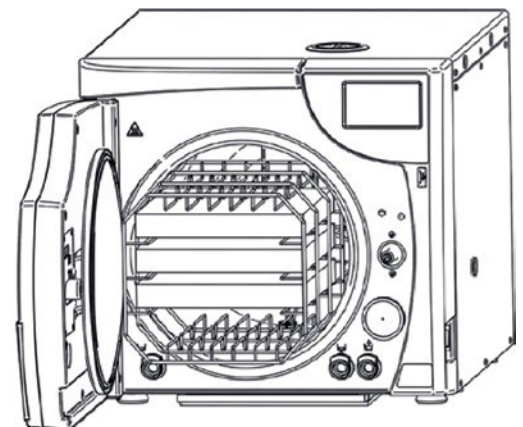

Be careful to lock the tray holder support in the chosen position by pushing it down until the locking pin is inserted.

8. STERILIZATION CYCLES

A sterilization cycle consists of a determined number of phases.

The number and duration of the phases can differ for the various cycles, based on the type of air extraction, sterilization process and drying methods:

- › **S 132°C Solid Unwrapped**
- › **S 132°C Solid Wrapped**
- › **S 132°C Hollow Unwrapped**
- › **B 132°C Hollow Wrapped**
- › **B 121°C Rubber & Plastic**
- › **Custom (user-defined)**

The electronic control system monitors the various phases, at the same time checking that the various parameters are respected; if any type of anomaly is encountered during the cycle, the program is immediately interrupted, generating an alarm identified by a code, with a relative message explaining the nature of the problem.

With this type of control, when you select a suitable sterilization program, effective sterilization will be achieved.

1. After inserting the load in the sterilization chamber (taking the precautions described in the section **PREPARATION OF THE MATERIAL**). Press CYCLES & TEST button to display the cycle selection buttons.

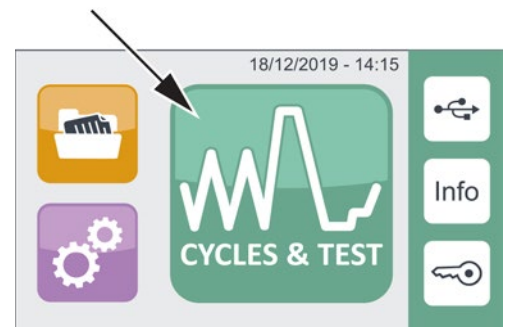

2. Press the button corresponding to the cycle chosen.



3. Start the cycle by pressing the indicated START button. The cycle counter appears in the upper left corner.

The following data are shown at the bottom:

- › Total cycle time
- › Process time
- › Rated process temperature
- › Rated process pressure

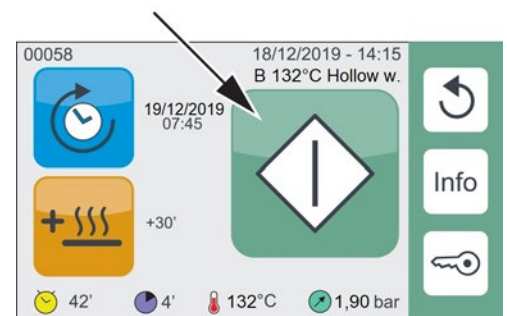

8.1 EXTRA DRYING

1. To set parameters, press and **HOLD** the following button until the screen changes to the Extra Drying settings listed below.

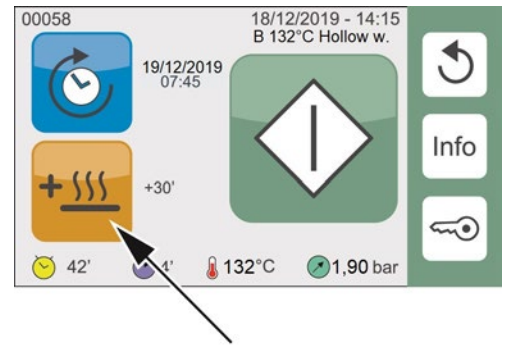

2. Set the minutes of drying you want to add to the standard drying time and confirm by pressing ENTER.

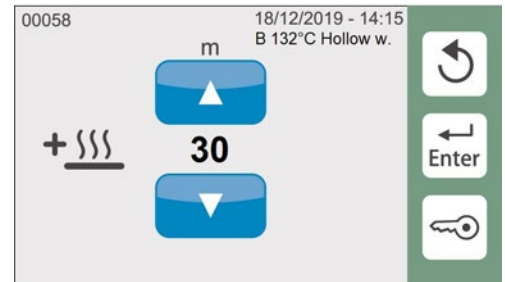

3. The selected value appears near the key. Activate the cycle.

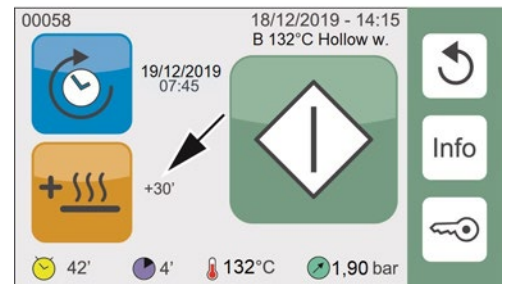

At next use, press the Extra Drying button to activate the values previously set.

Extra drying can be activated independently for each cycle.

8.2 DELAYED START

1. To set parameters, press and **HOLD** the following button until the screen changes to the Delayed Start settings listed below.

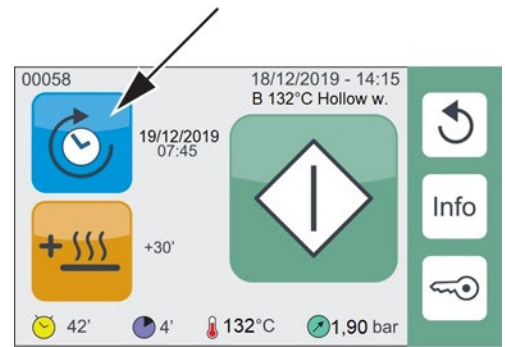

2. Set the time you want to start the cycle and confirm by pressing ENTER.



3. The selected time appears near the button. Press the START button; the cycle will automatically start at the set time.

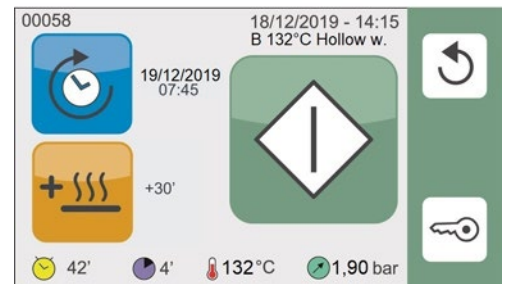

At next use, press the Delayed Start button to activate the values previously set.

8.3 EXECUTION OF THE CYCLE

Taking as an example the most complete and significant sterilization cycle, i.e. the B 132°C HOLLOW WRAPPED program, characterized by fractionated pre-vacuum, the cycle sequence is as follows:

1. Warming Up
2. First Vacuum Phase
3. First Pressure Rise
4. Second Vacuum Phase
5. Second Pressure Rise
6. Third Vacuum Phase
7. Third Pressure Rise
8. Sterilization
9. Steam Discharge
10. Drying
11. Ventilation
12. Cycle Completion

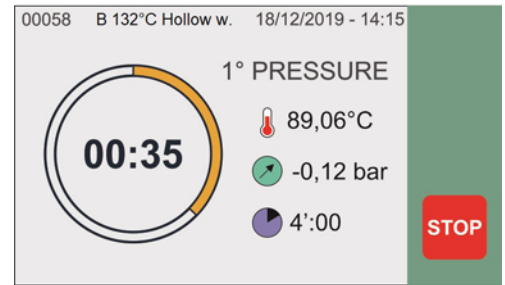

8.4 CYCLE OUTCOME

At the end of the cycle it is important to check the sterilization process outcome.

If the message “COMPLETED” is displayed, it means that the cycle has completed correctly without any alarm interruptions and that complete asepsis of the material is guaranteed.

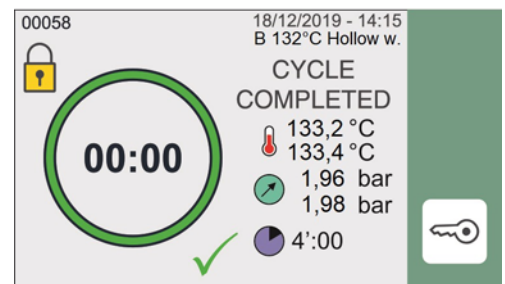

8.5 DOOR OPENING AT THE END OF THE CYCLE

To open the sterilizer door, press the DOOR UNLOCK button shown in the figure:

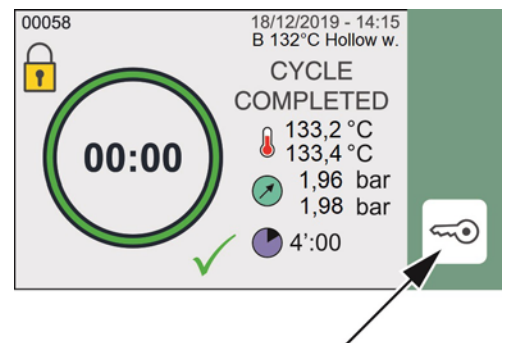

8.6 USER-DEFINED CYCLE

The Custom Cycle is intended for sterilization of medical devices that are not intended for patient contact and that have specific reprocessing requirements that cannot be met by the unit's existing validated sterilization cycles.

To use a Custom Cycle to sterilize medical devices that are not intended for patient contact, follow the device manufacturer's IFU concerning the selection of sterilization monitoring and packaging accessories.

1. To set parameters, select the following button:



2. **HOLD** down the following button to access settings:

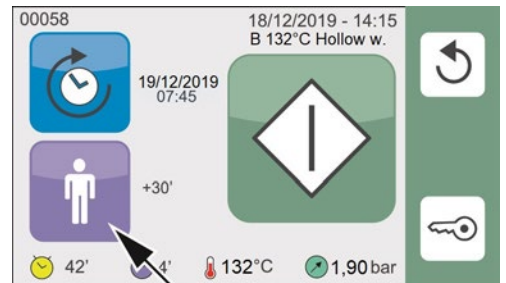

3. Select the type of pre-vacuum (fractionated or single), the process temperature, the exposure time and total drying time.

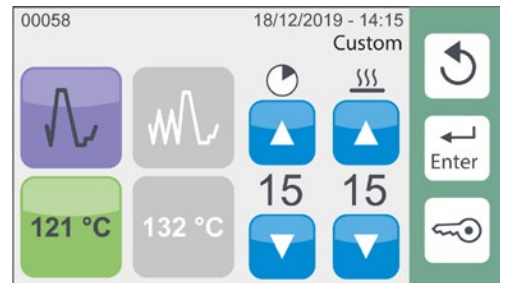

4. Once you have made the selections, press the ENTER button to save the settings and go back to the previous screen.
Press START button to start the user-defined cycle.

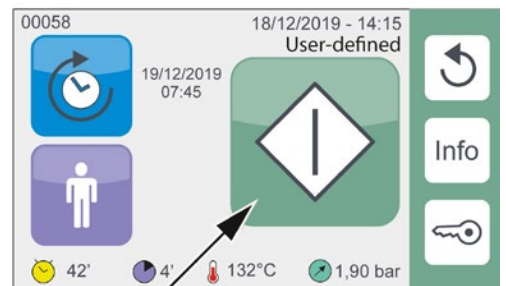

9. MATERIAL STORAGE

The sterilized material must be adequately treated and stored to maintain its sterility over time until its use.

Follow your local guidelines for proper material storage requirements.

Consult the specifications provided by the manufacturer of the packaging material relative to the maximum allowed storage time.

10. TEST PROGRAMS

To protect the safety of users and patients, a **fundamental** process like **sterilizing medical devices** should be periodically checked.

The device offers the possibility of easily and automatically executing two distinct test cycles:

- › **B&D TEST**
- › **VACUUM TEST**
- › A program that executes the two tests combined **VACUUM + B&D TEST** is also available
- › There is also a test to check the water quality: **H₂O TEST**

10.1 B&D CYCLE

B&D Test is a cycle run at 134° C characterized by a sterilization phase that lasts a specific time (3.5 minutes); the cycle comprises the fractionated vacuum phases similar to those used in the sterilization cycles.

Using an appropriate device, you can measure steam penetration into porous loads (Bowie & Dick test pack).

Load the appropriate B&D Test pack (see the section below for proper use of the test packs)

To use the **B&D Test cycle**, press the corresponding button and then press Start.

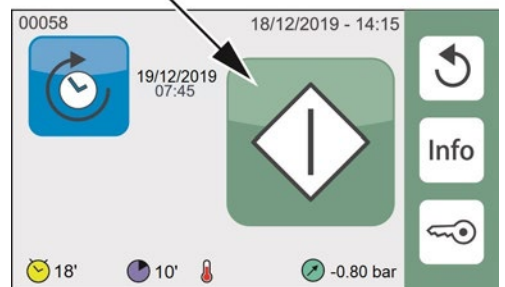
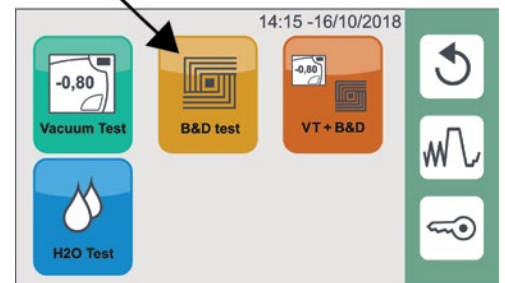
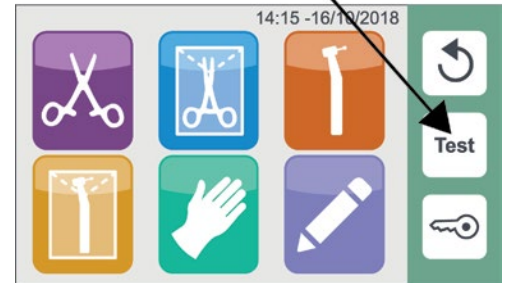

The BOWIE-DICK test is used to ensure proper air removal is occurring in a pre-vacuum autoclave. Complete air removal is important because pockets of cool air remaining in the chamber can compromise sterilization.

Using an FDA-approved Bowie-Dick test pack, the Bowie-Dick test runs a cycle at 134°C for 3.5 minutes to evaluate the correct air removal.

To perform a Bowie-Dick test, you will need a Bowie-Dick device or test pack. These are NOT supplied with your BRAVO G4. To perform the test, follow the instructions provided by the test manufacturer.

Place the test pack horizontally on the device's lowest tray, in the front part of the chamber, near the door. Do not put any other material inside the chamber. If the unit passes the test, it is ready for use. If the unit fails, check the test manufacturer's instructions and repeat the test.

10.2 VACUUM TEST CYCLE

The VACUUM TEST cycle allows testing perfect seal of the sterilizer hydraulic system.

Measuring the variation of the degree of vacuum in a defined time-frame and comparing it with pre-established limit values, you can determine how good the seal of the sterilization chamber, tubes and the various interception devices are.

1. To select the VACUUM TEST cycle, press the corresponding button and then press Start. The cycle must run with the sterilization chamber empty, and only the trays and their supports inserted.

We suggest running this test at the beginning of each working day with chamber at ambient temperature.

A high chamber temperature affects the variation in the vacuum value measured during the test; the system is therefore programmed to prevent execution of the test when the operating conditions are inadequate.

2. Close the door and start the program. The vacuum phase starts immediately and the pressure value (bar) and the countdown from the start of the test cycle are shown on the display.

If the pressure variation exceeds the limit defined, the program is interrupted and an alarm message generated. For the complete description of the alarms refer to the appendix.

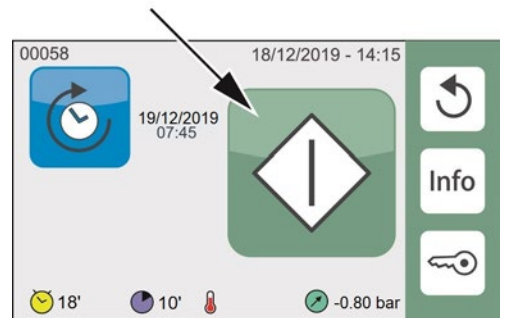
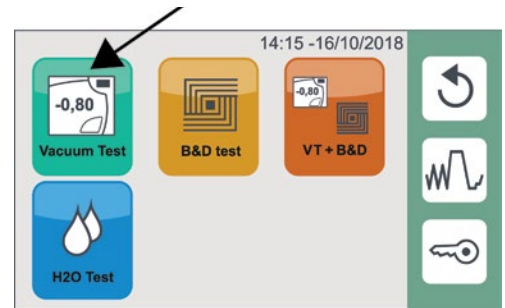

10.3 VACUUM TEST + B&D CYCLE

1. Select this option to run a VACUUM TEST cycle and a B&D cycle in sequence. To this end, place the test device on the central tray without inserting other material.
2. Close the door and start the cycle. The program will execute the two cycles in succession. Check the results as described in the previous paragraphs.

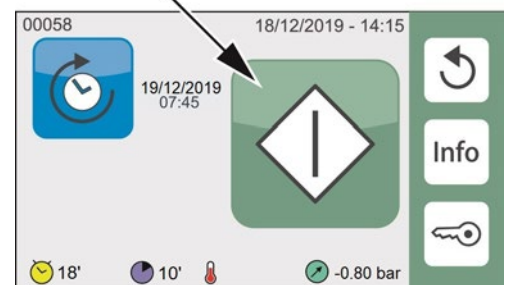
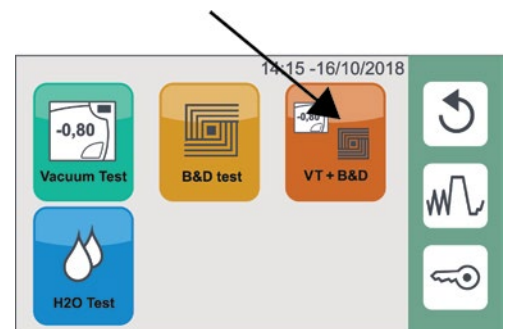

The presence of the Bowie & Dick test device does not alter the execution and the result of the Vacuum test cycle.

10.4 H2O TEST

Select this option to test the water quality.

The water conductivity is automatically measured at each sterilization or test cycle start and the relative value is indicated in the cycle report.

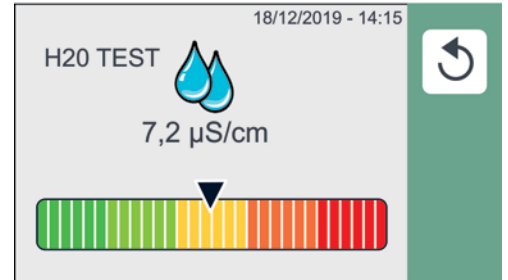
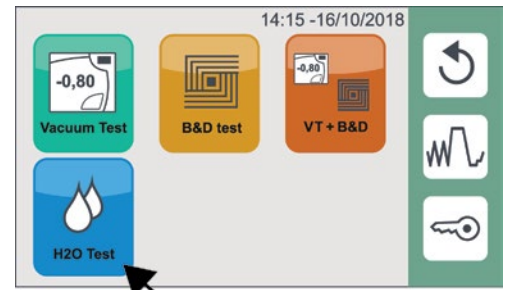

10.5 DOOR OPENING

1. To open the autoclave door, press and hold the button shown in the figure.

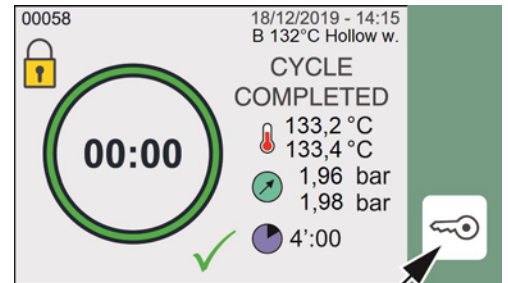

2. The door opens and stays ajar.

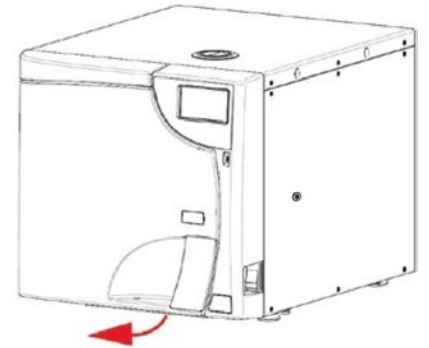

3. Now you can manually open the door.

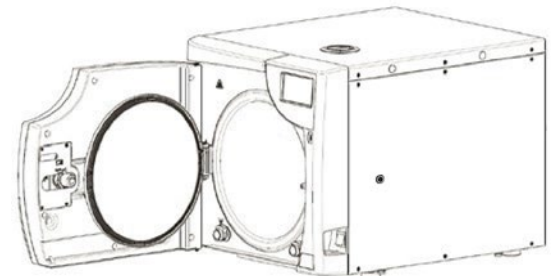

Keep the door closed, while not running the sterilization cycle, in order to ensure preheating achieves the max temperature level.

10.6 MANUAL INTERRUPTION

A cycle can be interrupted by the operator at any time, by **holding down the STOP button** indicated in the figure for about 3 seconds.

The command generates E999 error since the cycle could not finish correctly.

Press ENTER to proceed.

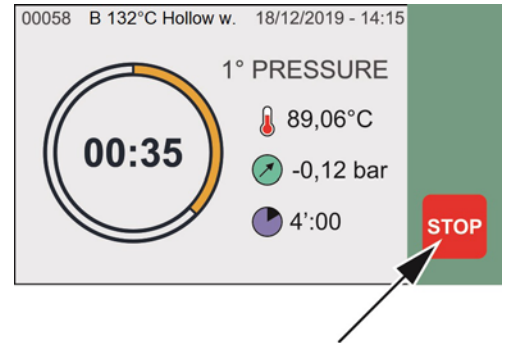

If the cycle is interrupted during certain phases, an automatic cleaning procedure of the internal hydraulic circuit starts. For the complete description of the alarms refer to "Alarms" appendix.

Press and hold RESET for about 3 seconds to open the door.

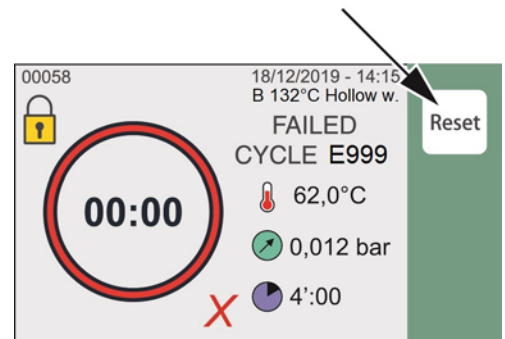

After a manual interruption of the program, the load must not be used since the sterilization is not ensured.

11. USED WATER DRAIN

The unit is equipped with an internal waste water tank, that collects the drainage water after each cycle.

When the maximum water level is reached, a specific message is displayed.

Proceed with draining the water tank by following the instructions listed below.

Open the door and continue as follows:

1. Prepare a basin with a capacity of at least 4 litres in proximity to the sterilizer; place the free end of the drain tube provided in the basin.
2. Insert the other end of the tube in the female union beneath the chamber inlet (connector on the left) pushing down until you hear a click.
3. Completely empty out the tank and then press on the upper part of the union to detach the tube quick coupling.

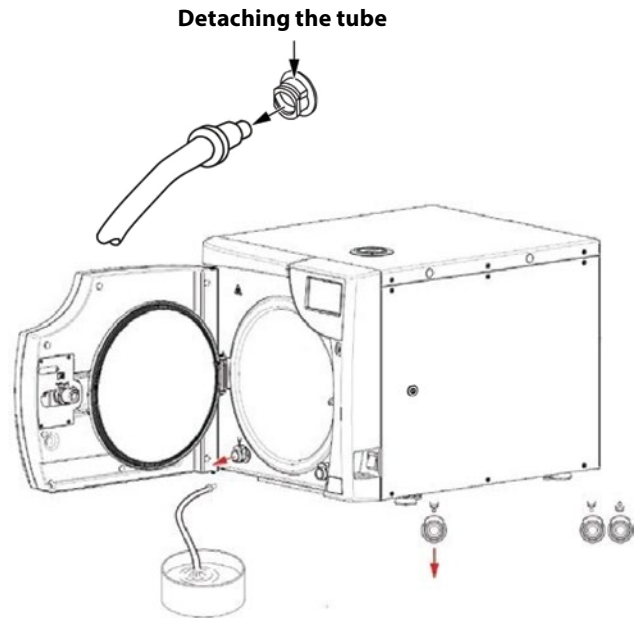

Do not open the tank doors during the cycle execution in order to prevent hot water leaks or spurts.

The unit can be connected, directly, to the centralized draining point. (ref. paragraph 4.6)

12. DATA MANAGEMENT & CONNECTIVITY

To access DATA MANAGEMENT & CONNECTIVITY section press the relevant icon.

DATA MANAGEMENT & CONNECTIVITY offers access to:

- › USB Management
- › WiFi
- › PRINTERS Management
- › ETHERNET
- › CLOUD connection



12.1 USB MANAGEMENT

Before carrying out the following operations insert the USB key.

It is possible to copy data about the cycles carried out, stored in the internal memory of the sterilizer, onto a USB key.

1. To download the sterilization cycles/tests select the following button:

The USB key must be formatted according to the instructions set forth in: Appendix - Technical Characteristics, summary table.

2. Insert the USB key into the front port as shown in the figure.

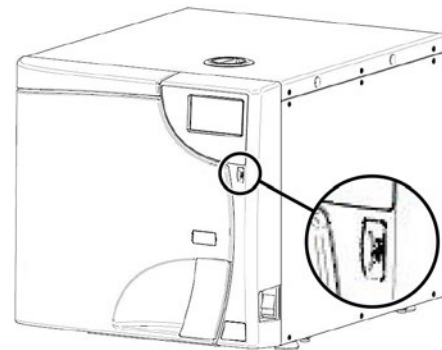
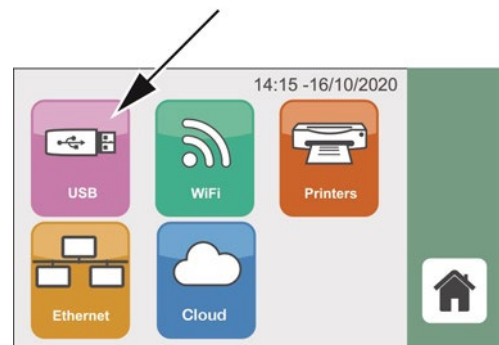

3. Before proceeding with the download you are required to select the report type and to choose the format:

- › Report (standard version)
- › Extended report

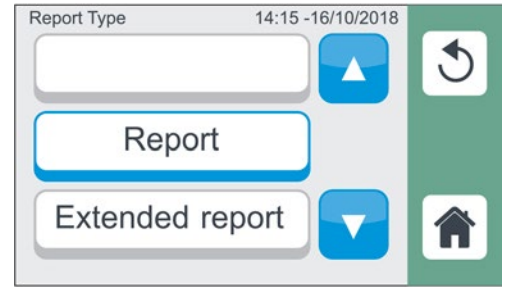

4. The sterilization / test cycle report files are in PDF format.

It is possible to select the number of cycles to download on the external storage device:

- › New
- › Last 10
- › Last 50
- › Last 100
- › Custom Mode

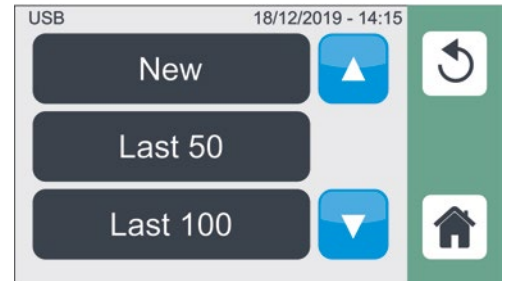

If Custom Mode is selected, you will be prompted to enter the number of the first and last cycle to download. At the end of the download remove the USB key.

When a preset number of cycles is exceeded, the system generates a warning about the need to carry out a backup of data contained in the internal memory.

To delete the warning displayed, download the cycle reports using the New option.



Do not turn on the sterilizer if the USB key is inserted.

The unit scans for new software updates anytime a USB is inserted and the machine is turned on. Only insert the USB stick when you need to download cycles and when performing software updates (for SERVICE only).

DIRECT DOWNLOAD

This control performs the download of NEW cycle reports, as PDF file, by means of a USB key. NEW indicates the cycle reports have not been previously downloaded.

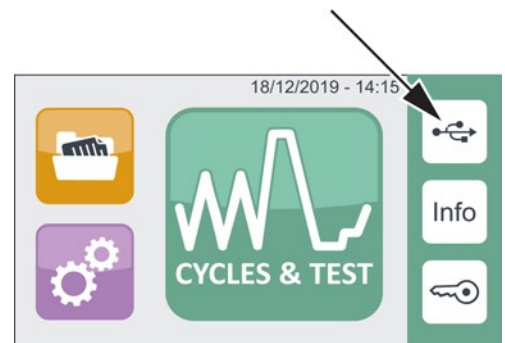

12.2 WIFI

1. Select WiFi to connect the sterilizer to a local WiFi network.

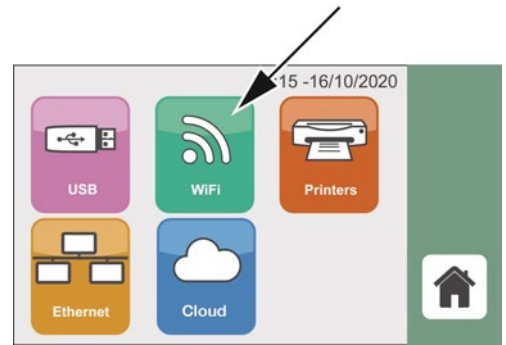

2. Select ON/OFF to enable or disable WiFi connection. Confirm by pressing ENTER. Select SETTINGS button to configure the WiFi network.

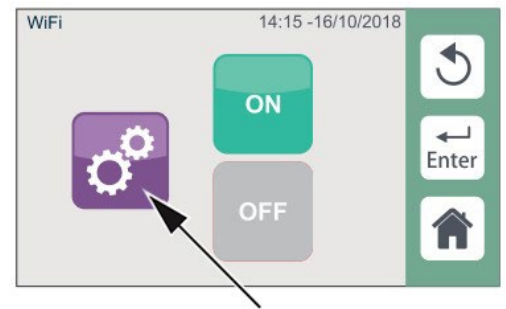

3. WiFi SETTING offers access to:

- › NETWORKS SEARCH
- › MANUAL ENTRY
- › SETUP

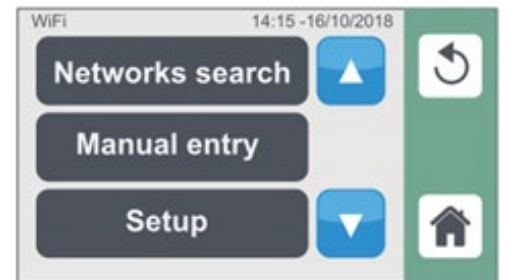

4. NETWORKS SEARCH automatically searches for available WiFi networks, displayed as a list. Scroll the list to select the WiFi network and confirm by pressing ENTER.

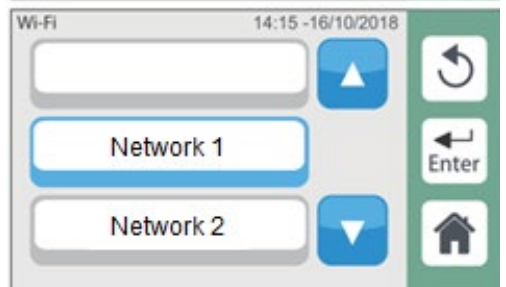

- Following the selection of the network name, enter the network PASSWORD and confirm by pressing ENTER.
SHIFT button allows special characters keyboard.



- MANUAL ENTRY allows the user to manually enter the WiFi network SSID and PASSWORD and confirm by pressing ENTER.
Pressing SSID or PSW button displays the editing keyboard.

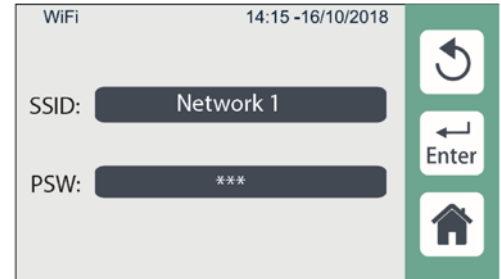

- DHCP can be set as Automatic or Manual.
In Automatic DHCP mode, the network configuration parameters are automatically assigned.
In Manual DHCP mode, the network configuration parameters must be set manually.

Confirm the selected mode by pressing ENTER.

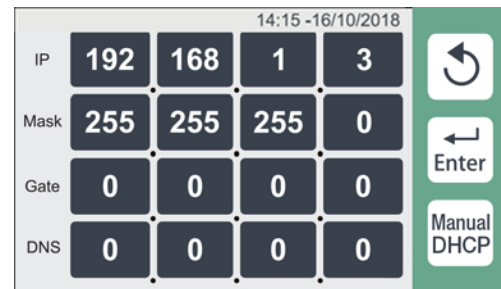

12.3 PRINTERS

1. To set parameters select the following item:

Only the optional external printer Ref. M7D200012 is compatible with the BRAVO G4.
Refer to the printer manual for startup and paper loading.

2. Select PRINTERS to choose the support / mode to be used between:
 - › NO PRINTER - deactivates the printer.
 - › REPORT - prints a compact version of the cycle summary report at the end of the process.
 - › EXTENDED REPORT - prints an extended version of the cycle summary report at the end of the process.
 - › BARCODE LABELS - prints the labels bearing the cycle data and the barcode.
3. At the end of the cycle, press DOOR UNLOCK button.

4. If the BARCODE LABELS mode is selected, the following screen is displayed, from which it is possible to set the number of labels and the interval, in days, between the cycle execution date and the sterilized material expiry date.
Use the arrows to adjust the value.
Press the PRINTER button to print the labels complete with barcode.
5. In case of an unsuccessful cycle or test cycle, only one label will be automatically printed.
If the printer is connected to the autoclave and REPORT option is set, the sterilizer automatically prints the summary report at the end of the cycle.

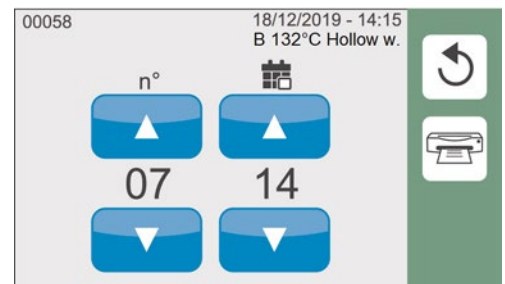
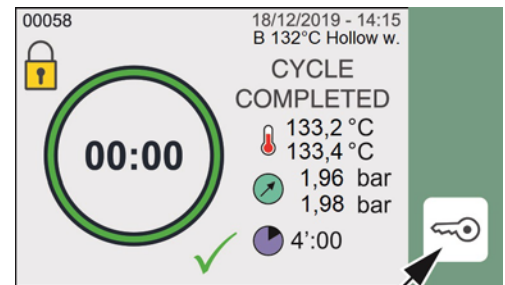

12.4 ETHERNET

1. Select ETHERNET to connect the sterilizer to a local Ethernet network.

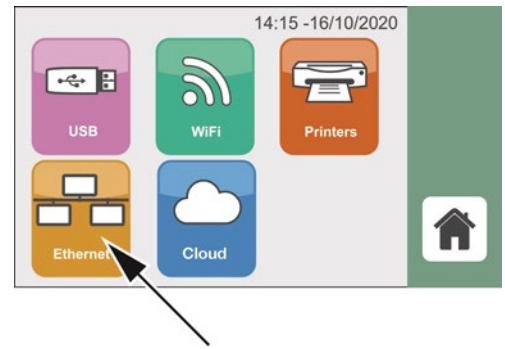

2. DHCP can be set as Automatic or Manual. In Automatic DHCP mode, the network configuration parameters are automatically assigned. In Manual DHCP mode, the network configuration parameters must be set manually.

Confirm the selected mode by pressing ENTER.

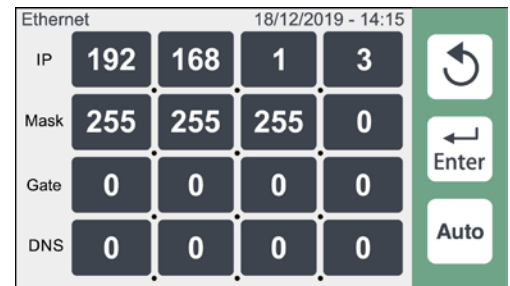

12.5 G4 CLOUD

1. The BRAVO G4 Cloud web portal is a direct connection to the BRAVO G4 on your local area network. It is protected by your firewall and not accessible to outside users (unless they have a Remote Access Code). For more information, please contact the Technical Service Department for retrieving Remote Access Code.

The G4 Cloud web portal provides real-time cycle information and archived sterilization records unique to this unit. From here, you can print reports, set up email notifications and search cycle histories. To set up the web portal, please follow the below instructions; additional information is available on the portal's 'HELP' tab.

2. Once network connection is complete, select the Cloud icon to setup SciCan Online Access. The Online Activation Code or QR Code will automatically display on the screen. Using the Online Access Activation Code, please follow the instructions listed on www.scican.com/online-access or use the QR-Code for faster URL access.

Online Access can be completed at any time (the unit must be connected to WiFi or Ethernet network).

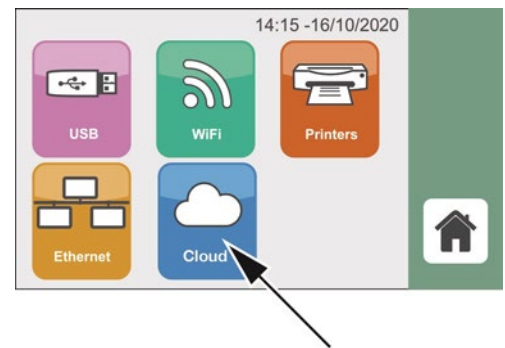

13. APPENDIX – PROGRAMS

Steam sterilization is suitable for almost all the materials and instruments, provided that they can bear without damage a minimum temperature of 121°C (if this is not the case, other low-temperature sterilization systems must be used).

The following material can normally be sterilized with steam:

- › Stainless steel surgical/generic instruments
- › Carbon steel surgical/generic instruments
- › Rotating and/or vibrating instruments driven by compressed air (turbines) or mechanical transmission (contra angles, tooth scalers)
- › Glass items
- › Mineral-based items
- › Heat-resistant plastic items
- › Heat-resistant rubber items
- › Heat-resistant textiles
- › Medication materials (gauze, pads, etc.)
- › Other generic material suitable for autoclave treatment

Depending on the material (solid, hollow or porous), on any package containing it (paper/plastic pouch, paper for sterilization, container, muslin napkins, etc.) and on its resistance to heat, it is essential to choose the suitable sterilization program, referring to the table in the next page.



The device must not be used for the sterilization of fluids, liquids or pharmaceutical products.

13.1 SUMMARY TABLE OF 17 - 120 V CYCLES

PROGRAM NAME	CYCLE TYPE (*)	STERILIZATION TEMPERATURE AND TIME	DRYING TIME (min) (***)	CYCLE TIME MAX. LOAD (min) (***)	MAXIMUM LOAD (**) (***)	TYPE	MAX. MASS PER TRAY (kg) **
132°C SOLID UN-WRAPPED	PREVACUUM (1 steps; -0.8 bar)	132°C / 270°F 4 min	4	33	6 kg 13.23 lbs	Unwrapped metal instruments	max 1.2 kg per tray (2.65 lbs)
132°C SOLID WRAPPED	PREVACUUM (1 steps; -0.8 bar)	132°C / 270°F 4 min	13	42	3 kg 6.61 lbs	Single wrapped cassettes with metal instruments Single wrapped or pouched metal instruments	max 1 kg per tray or cassettes (2.21 lbs)
					6 kg 13.23 lbs	Unwrapped metal instruments	max 1.2 kg per tray (2.65 lbs)
132° HOLLOW UN-WRAPPED	PREVACUUM (3 steps; -0.8 bar each step)	132°C / 270°F 4 min	4	50	6 kg 13.23 lbs	Unwrapped metal instruments and dental handpieces	max 1.2 kg per tray (2.65 lbs)
132°C HOLLOW WRAPPED	PREVACUUM (3 steps; -0.8 bar each step)	132°C / 270°F 4 min	13	59	1 kg 2.21 lbs	Unwrapped porous and fabric textiles	max 0.3 kg per tray (0.66 lbs)
					0.75 kg 1.65 lbs	Single wrapped porous and fabric textiles	max 0.25 kg per tray (0.55 lbs)
					0.60 kg 1.32 lbs	Double wrapped porous and fabric textiles	max 0.2 kg per tray (0.44 lbs)
					6 kg 13.23 lbs	Unwrapped metal instruments and dental handpieces	max 1.2 kg per tray (2.65 lbs)
					3 kg 6.61 lbs	Single wrapped or pouched metal instruments and dental handpieces Single wrapped cassettes with metal instruments and dental handpieces	max 1 kg per tray or cassettes (2.21 lbs)
					1.5 kg 3.31 lbs	Double pouched metal instruments and dental handpieces	max 0.5 kg per tray (1.10 lbs)

SUMMARY TABLE OF 17 - 120 V CYCLES cont.

PROGRAM NAME	CYCLE TYPE (*)	STERILIZATION TEMPERATURE AND TIME	DRYING TIME (min) (***)	CYCLE TIME MAX. LOAD (min) (***)	MAXIMUM LOAD (**) (**)	TYPE	MAX. MASS PER TRAY (kg) **
121°C RUBBER & PLASTIC	PREVACUUM (3 steps; -0.8 bar each step)	121°C / 250°F 20 min	13	75	1 kg 2.21 lbs	Unwrapped porous and fabric textiles	max 0.3 kg per tray (0.66 lbs)
					0.75 kg 1.65 lbs	Single wrapped porous and fabric textiles	max 0.25 kg per tray (0.55 lbs)
					0.60 kg 1.32 lbs	Double wrapped porous and fabric textiles	max 0.2 kg per tray (0.44 lbs)
					6 kg 13.23 lbs	Unwrapped metal or polymer instruments and dental handpieces	max 1.2 kg per tray (2.65 lbs)
					3 kg 6.61 lbs	Single wrapped or pouched metal or polymer instruments and dental handpieces	max 1 kg per tray or cassettes (2.21 lbs)
						Single wrapped cassettes with metal or polymer instruments and dental handpieces	
1.5 kg 3.31 lbs	Double pouched metal or polymer instruments and dental handpieces	max 0.5 kg per tray (1.10 lbs)					
CUSTOM (****)	PREVACUUM (1 or 3 steps; -0.8 bar each)	132°C / 270°F 4 - 30 min or 121°C / 250°F 20 - 30 min	5 ÷ 30	–	For the user defined cycle, the maximum load inserted (e.g., “unwrapped”, “solid”, etc.) and on the parameters set by the user for that cycle. According to these aspects, refer to the loads of the cycles above with fixed parameters in this table.		
134°C B&D TEST	PREVACUUM (3 steps; -0.8 bar each step)	134°C / 273°F 3.5 minutes	1	23	–	PREVACUUM (3 steps; -0.8 bar each step)	134°C / 273°F 3.5 min
VACUUM TEST	Vacuum (-0.8 bar)	–	–	18	–	Vacuum (-0.8 bar)	–
VACUUM + B&D TEST	–	–	–	–	–	–	–

(*) Single Pre-Vacuum = 1 pre-vacuum; -0.8 bar (see figures in the following pages).

Fractionated Pre-Vacuum = 3 pre-vacuum; -0.8 bar each (see figures in the following pages).

(**) The Max. Mass per Tray means the maximum load to be placed on each tray, respecting the MAX. TOTAL MASS as device load limit.

(***) Depending on the type of load, it may be necessary to optimize drying using the extra drying function (8.1).

(****) The Custom Cycle is intended for sterilization of medical devices that are not intended for patient contact and that have specific reprocessing requirements that cannot be met by the unit’s existing validated sterilization cycles.

To use a Custom Cycle to sterilize medical devices that are not intended for patient contact, follow the device manufacturer’s IFU concerning the selection of sterilization monitoring and packaging accessories.

It is important to consult the instrument manufacturer’s reprocessing instructions to confirm instruments can tolerate steam sterilization temperatures.

13.2 SUMMARY TABLE OF 17 - 240 V CYCLES

PROGRAM NAME	CYCLE TYPE (*)	STERILIZATION TEMPERATURE AND TIME	DRYING TIME (min) (***)	CYCLE TIME MAX. LOAD (min) (***)	MAXIMUM LOAD (**) (***)	TYPE	MAX. MASS PER TRAY (kg) **
132°C SOLID UN-WRAPPED	PREVACUUM (1 steps; -0.8 bar)	132°C / 270°F 4 min	4	27	6 kg 13.23 lbs	Unwrapped metal instruments	max 1.2 kg per tray (2.65 lbs)
132°C SOLID WRAPPED	PREVACUUM (1 steps; -0.8 bar)	132°C / 270°F 4 min	13	36	3 kg 6.61 lbs	Single wrapped cassettes with metal instruments Single wrapped or pouched metal instruments	max 1 kg per tray or cassettes (2.21 lbs)
					6 kg 13.23 lbs	Unwrapped metal instruments	max 1.2 kg per tray (2.65 lbs)
132° HOLLOW UN-WRAPPED	PREVACUUM (3 steps; -0.8 bar each step)	132°C / 270°F 4 min	4	38	6 kg 13.23 lbs	Unwrapped metal instruments and dental handpieces	max 1.2 kg per tray (2.65 lbs)
132°C HOLLOW WRAPPED	PREVACUUM (3 steps; -0.8 bar each step)	132°C / 270°F 4 min	13	47	1 kg 2.21 lbs	Unwrapped porous and fabric textiles	max 0.3 kg per tray (0.66 lbs)
					0.75 kg 1.65 lbs	Single wrapped porous and fabric textiles	max 0.25 kg per tray (0.55 lbs)
					0.60 kg 1.32 lbs	Double wrapped porous and fabric textiles	max 0.2 kg per tray (0.44 lbs)
					6 kg 13.23 lbs	Unwrapped metal instruments and dental handpieces	max 1.2 kg per tray (2.65 lbs)
					3 kg 6.61 lbs	Single wrapped or pouched metal instruments and dental handpieces Single wrapped cassettes with metal instruments and dental handpieces	max 1 kg per tray or cassettes (2.21 lbs)
					1.5 kg 3.31 lbs	Double pouched metal instruments and dental handpieces	max 0.5 kg per tray (1.10 lbs)

SUMMARY TABLE OF 17 - 240 V CYCLES cont.

PROGRAM NAME	CYCLE TYPE (*)	STERILIZATION TEMPERATURE AND TIME	DRYING TIME (min) (***)	CYCLE TIME MAX. LOAD (min) (***)	MAXIMUM LOAD (**) (***)	TYPE	MAX. MASS PER TRAY (kg) **
121°C RUBBER & PLASTIC	PREVACUUM (3 steps; -0.8 bar each step)	121°C / 250°F 20 min	13	62	1 kg 2.21 lbs	Unwrapped porous and fabric textiles	max 0.3 kg per tray (0.66 lbs)
					0.75 kg 1.65 lbs	Single wrapped porous and fabric textiles	max 0.25 kg per tray (0.55 lbs)
					0.60 kg 1.32 lbs	Double wrapped porous and fabric textiles	max 0.2 kg per tray (0.44 lbs)
					6 kg 13.23 lbs	Unwrapped metal or polymer instruments and dental handpieces	max 1.2 kg per tray (2.65 lbs)
					3 kg 6.61 lbs	Single wrapped or pouched metal or polymer instruments and dental handpieces Single wrapped cassettes with metal or polymer instruments and dental handpieces	max 1 kg per tray or cassettes (2.21 lbs)
					1.5 kg 3.31 lbs	Double pouched metal or polymer instruments and dental handpieces	max 0.5 kg per tray (1.10 lbs)
CUSTOM (****)	PREVACUUM (1 or 3 steps; -0.8 bar each)	132°C / 270°F 4 - 30 min or 121°C / 250°F 20 - 30 min	5 ÷ 30	-	For the user defined cycle, the maximum load inserted (e.g., "unwrapped", "solid", etc.) and on the parameters set by the user for that cycle. According to these aspects, refer to the loads of the cycles above with fixed parameters in this table.		
134°C B&D TEST	PREVACUUM (3 steps; -0.8 bar each step)	134°C / 273°F 3.5 minutes	1	20	-	PREVACUUM (3 steps; -0.8 bar each step)	134°C / 273°F 3.5 min
VACUUM TEST	Vacuum (-0.8 bar)	-	-	18	-	Vacuum (-0.8 bar)	-
VACUUM + B&D TEST	-	-	-	-	-	-	-

(*) Single Pre-Vacuum = 1 pre-vacuum; -0.8 bar (see figures in the following pages).

Fractionated Pre-Vacuum = 3 pre-vacuum; -0.8 bar each (see figures in the following pages).

(**) The Max. Mass per Tray means the maximum load to be placed on each tray, respecting the MAX. TOTAL MASS as device load limit.

(***) Depending on the type of load, it may be necessary to optimize drying using the extra drying function (8.1).

(****) The Custom Cycle is intended for sterilization of medical devices that are not intended for patient contact and that have specific reprocessing requirements that cannot be met by the unit's existing validated sterilization cycles. To use a Custom Cycle to sterilize medical devices that are not intended for patient contact, follow the device manufacturer's IFU concerning the selection of sterilization monitoring and packaging accessories.

It is important to consult the instrument manufacturer's reprocessing instructions to confirm instruments can tolerate steam sterilization temperatures.

13.3 SUMMARY TABLE OF 22 - 120 V CYCLES

PROGRAM NAME	CYCLE TYPE (*)	STERILIZATION TEMPERATURE AND TIME	DRYING TIME (min) (***)	CYCLE TIME MAX. LOAD (min) (***)	MAXIMUM LOAD (**) (***)	TYPE	MAX. MASS PER TRAY (kg) **
132°C SOLID UN-WRAPPED	PREVACUUM (1 steps; -0.8 bar)	132°C / 270°F 4 min	25	42	7.5 kg 16.53 lbs	Unwrapped metal instruments	max 1.5 kg per tray (3.31 lbs)
132°C SOLID WRAPPED	PREVACUUM (1 steps; -0.8 bar)	132°C / 270°F 4 min	15	52	4 kg 8.82 lbs	Single wrapped cassettes with metal instruments Single wrapped or pouched metal instruments	max 1.25 kg per tray or cassettes (2.76 lbs)
					7.5 kg 16.53 lbs	Unwrapped metal instruments	max 1.5 kg per tray (3.31 lbs)
132° HOLLOW UN-WRAPPED	PREVACUUM (3 steps; -0.8 bar each step)	132°C / 270°F 4 min	5	63	7.5 kg 16.53 lbs	Unwrapped metal instruments and dental handpieces	max 1.5 kg per tray (3.31 lbs)
132°C HOLLOW WRAPPED	PREVACUUM (3 steps; -0.8 bar each step)	132°C / 270°F 4 min	15	73	1.2 kg 2.65 lbs	Unwrapped porous and fabric textiles	max 0.4 kg per tray (0.88 lbs)
					1 kg 2.21 lbs	Single wrapped porous and fabric textiles	max 0.3 kg per tray (0.66 lbs)
					0.75 kg 1.65 lbs	Double wrapped porous and fabric textiles	max 0.2 kg per tray (0.44 lbs)
					7.5 kg 16.53 lbs	Unwrapped metal instruments and dental handpieces	max 1.5 kg per tray (3.31 lbs)
					4 kg 8.82 lbs	Single wrapped or pouched metal instruments and dental handpieces Single wrapped cassettes with metal instruments and dental handpieces	max 1.25 kg per tray or cassettes (2.76 lbs)
					2 kg 4.41 lbs	Double pouched metal instruments and dental handpieces	max 0.6 kg per tray (1.32 lbs)

SUMMARY TABLE OF 22 - 120 V CYCLES cont.

PROGRAM NAME	CYCLE TYPE (*)	STERILIZATION TEMPERATURE AND TIME	DRYING TIME (min) (***)	CYCLE TIME MAX. LOAD (min) (***)	MAXIMUM LOAD (**) (***)	TYPE	MAX. MASS PER TRAY (kg) **
121°C RUBBER & PLASTIC	PREVACUUM (3 steps; -0.8 bar each step)	121°C / 250°F 20 min	15	89	1.2 kg 2.65 lbs	Unwrapped porous and fabric textiles	max 0.4 kg per tray (0.88 lbs)
					1 kg 2.21 lbs	Single wrapped porous and fabric textiles	max 0.3 kg per tray (0.66 lbs)
					0.75 kg 1.65 lbs	Double wrapped porous and fabric textiles	max 0.25 kg per tray (0.55 lbs)
					7.5 kg 16.53 lbs	Unwrapped metal or polymer instruments and dental handpieces	max 1.5 kg per tray (3.31 lbs)
					4 kg 8.82 lbs	Single wrapped or pouched metal or polymer instruments and dental handpieces Single wrapped cassettes with metal or polymer instruments and dental handpieces	max 1.25 kg per tray or cassettes (2.76 lbs)
					2 kg 4.41 lbs	Double pouched metal or polymer instruments and dental handpieces	max 0.6 kg per tray (1.32 lbs)
CUSTOM (****)	PREVACUUM (1 or 3 steps; -0.8 bar each)	132°C / 270°F 4 - 30 min or 121°C / 250°F 20 - 30 min	5 ÷ 30	-	For the user defined cycle, the maximum load inserted (e.g., "unwrapped", "solid", etc.) and on the parameters set by the user for that cycle. According to these aspects, refer to the loads of the cycles above with fixed parameters in this table.		
134°C B&D TEST	PREVACUUM (3 steps; -0.8 bar each step)	134°C / 273°F 3.5 minutes	1	28	-	PREVACUUM (3 steps; -0.8 bar each step)	134°C / 273°F 3.5 min
VACUUM TEST	Vacuum (-0.8 bar)	-	-	18	-	Vacuum (-0.8 bar)	-
VACUUM + B&D TEST	-	-	-	-	-	-	-

(*) Single Pre-Vacuum = 1 pre-vacuum; -0.8 bar (see figures in the following pages).

Fractionated Pre-Vacuum = 3 pre-vacuum; -0.8 bar each (see figures in the following pages).

(**) The Max. Mass per Tray means the maximum load to be placed on each tray, respecting the MAX. TOTAL MASS as device load limit.

(***) Depending on the type of load, it may be necessary to optimize drying using the extra drying function (8.1).

(****) The Custom Cycle is intended for sterilization of medical devices that are not intended for patient contact and that have specific reprocessing requirements that cannot be met by the unit's existing validated sterilization cycles. To use a Custom Cycle to sterilize medical devices that are not intended for patient contact, follow the device manufacturer's IFU concerning the selection of sterilization monitoring and packaging accessories.

It is important to consult the instrument manufacturer's reprocessing instructions to confirm instruments can tolerate steam sterilization temperatures.

13.4 SUMMARY TABLE OF 22 - 240 V CYCLES

PROGRAM NAME	CYCLE TYPE (*)	STERILIZATION TEMPERATURE AND TIME	DRYING TIME (min) (***)	CYCLE TIME MAX. LOAD (min) (***)	MAXIMUM LOAD (**) (***)	TYPE	MAX. MASS PER TRAY (kg) **
132°C SOLID UN-WRAPPED	PREVACUUM (1 steps; -0.8 bar)	132°C / 270°F 4 min	5	32	7.5 kg 16.53 lbs	Unwrapped metal instruments	max 1.5 kg per tray (3.31 lbs)
132°C SOLID WRAPPED	PREVACUUM (1 steps; -0.8 bar)	132°C / 270°F 4 min	15	42	4 kg 8.82 lbs	Single wrapped cassettes with metal instruments Single wrapped or pouched metal instruments	max 1.25 kg per tray or cassettes (2.76 lbs)
					7.5 kg 16.53 lbs	Unwrapped metal instruments	max 1.5 kg per tray (3.31 lbs)
132° HOLLOW UN-WRAPPED	PREVACUUM (3 steps; -0.8 bar each step)	132°C / 270°F 4 min	5	46	7.5 kg 16.53 lbs	Unwrapped metal instruments and dental handpieces	max 1.5 kg per tray (3.31 lbs)
132°C HOLLOW WRAPPED	PREVACUUM (3 steps; -0.8 bar each step)	132°C / 270°F 4 min	15	56	1.2 kg 2.65 lbs	Unwrapped porous and fabric textiles	max 0.4 kg per tray (0.88 lbs)
					1 kg 2.21 lbs	Single wrapped porous and fabric textiles	max 0.3 kg per tray (0.66 lbs)
					0.75 kg 1.65 lbs	Double wrapped porous and fabric textiles	max 0.2 kg per tray (0.44 lbs)
					7.5 kg 16.53 lbs	Unwrapped metal instruments and dental handpieces	max 1.5 kg per tray (3.31 lbs)
					4 kg 8.82 lbs	Single wrapped or pouched metal instruments and dental handpieces Single wrapped cassettes with metal instruments and dental handpieces	max 1.25 kg per tray or cassettes (2.76 lbs)
					2 kg 4.41 lbs	Double pouched metal instruments and dental handpieces	max 0.6 kg per tray (1.32 lbs)

SUMMARY TABLE OF 22 - 240 V CYCLES cont.

PROGRAM NAME	CYCLE TYPE (*)	STERILIZATION TEMPERATURE AND TIME	DRYING TIME (min) (***)	CYCLE TIME MAX. LOAD (min) (***)	MAXIMUM LOAD (**) (***)	TYPE	MAX. MASS PER TRAY (kg) **
121°C RUBBER & PLASTIC	PREVACUUM (3 steps; -0.8 bar each step)	121°C / 250°F 20 min	15	71	1.2 kg 2.65 lbs	Unwrapped porous and fabric textiles	max 0.4 kg per tray (0.88 lbs)
					1 kg 2.21 lbs	Single wrapped porous and fabric textiles	max 0.3 kg per tray (0.66 lbs)
					0.75 kg 1.65 lbs	Double wrapped porous and fabric textiles	max 0.25 kg per tray (0.55 lbs)
					7.5 kg 16.53 lbs	Unwrapped metal or polymer instruments and dental handpieces	max 1.5 kg per tray (3.31 lbs)
					4 kg 8.82 lbs	Single wrapped or pouched metal or polymer instruments and dental handpieces Single wrapped cassettes with metal or polymer instruments and dental handpieces	max 1.25 kg per tray or cassettes (2.76 lbs)
					2 kg 4.41 lbs	Double pouched metal or polymer instruments and dental handpieces	max 0.6 kg per tray (1.32 lbs)
CUSTOM (****)	PREVACUUM (1 or 3 steps; -0.8 bar each)	132°C / 270°F 4 - 30 min or 121°C / 250°F 20 - 30 min	5 ÷ 30	–	For the user defined cycle, the maximum load inserted (e.g., “unwrapped”, “solid”, etc.) and on the parameters set by the user for that cycle. According to these aspects, refer to the loads of the cycles above with fixed parameters in this table.		
134°C B&D TEST	PREVACUUM (3 steps; -0.8 bar each step)	134°C / 273°F 3.5 minutes	1	22	–	PREVACUUM (3 steps; -0.8 bar each step)	134°C / 273°F 3.5 min
VACUUM TEST	Vacuum (-0.8 bar)	–	–	18	–	Vacuum (-0.8 bar)	–
VACUUM + B&D TEST	–	–	–	–	–	–	–

(*) Single Pre-Vacuum = 1 pre-vacuum; -0.8 bar (see figures in the following pages).

Fractionated Pre-Vacuum = 3 pre-vacuum; -0.8 bar each (see figures in the following pages).

(**) The Max. Mass per Tray means the maximum load to be placed on each tray, respecting the MAX. TOTAL MASS as device load limit.

(***) Depending on the type of load, it may be necessary to optimize drying using the extra drying function (8.1).

(****) The Custom Cycle is intended for sterilization of medical devices that are not intended for patient contact and that have specific reprocessing requirements that cannot be met by the unit's existing validated sterilization cycles.

To use a Custom Cycle to sterilize medical devices that are not intended for patient contact, follow the device manufacturer's IFU concerning the selection of sterilization monitoring and packaging accessories.

It is important to consult the instrument manufacturer's reprocessing instructions to confirm instruments can tolerate steam sterilization temperatures.

PRESSURE, TIME AND TEMPERATURE

132°C cycles

		Time (minutes)	Min. temperature	Max. temperature	Min. pressure (bar)	Max. pressure (bar)
1	CS	–	–	–	–	–
t1	1PV	–	–	–	-0.81	-0.79
t2	1PP	–	–	–	+0.97	+1.03
t3	2PV	–	–	–	-0.81	-0.79
t4	2PP	–	–	–	+0.97	+1.03
t5	3PV	–	–	–	-0.81	-0.79
t6	SS	4	+132	+135	+ 1.86	+ 2.13
t7	SE	4	+132	+135	+ 1.86	+ 2.13
t8	DS	–	–	–	-0.81	-0.79
t9	DE	–	–	–	---	---
2	CE	–	–	–	-0.02	+0.02

121°C cycles

		Time (minutes)	Min. temperature	Max. temperature	Min. pressure (bar)	Max. pressure (bar)
1	CS	–	–	–	–	–
t1	1PV	–	–	–	-0.81	-0.79
t2	1PP	–	–	–	+0.97	+1.03
t3	2PV	–	–	–	-0.81	-0.79
t4	2PP	–	–	–	+0.97	+1.03
t5	3PV	–	–	–	-0.81	-0.79
t6	SS	20	+121	+124	+1.04	+1.24
t7	SE	20	+121	+124	+1.04	+1.24
t8	DS	–	–	–	-0.81	-0.79
t9	DE	–	–	–	–	–
2	CE	–	–	–	-0.02	+0.02

13.5 STERILIZATION PROGRAM DIAGRAM

PROGRAM
S 132°C SOLID WRAPPED
132°C – 4 minutes

- A** PRESSURE (BAR)
- B** PROCESS
- C** TIME (MIN)
- I** SINGLE PRE-VACUUM
- G** LONG DRYING

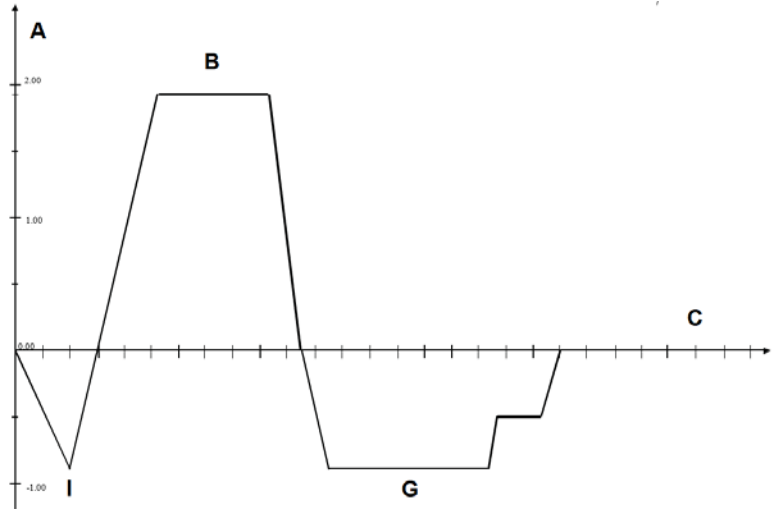

PROGRAM
S 132°C SOLID UNWRAPPED
132°C – 4 minutes

- A** PRESSURE (BAR)
- B** PROCESS
- C** TIME (MIN)
- F** SINGLE PRE-VACUUM
- H** SHORT DRYING

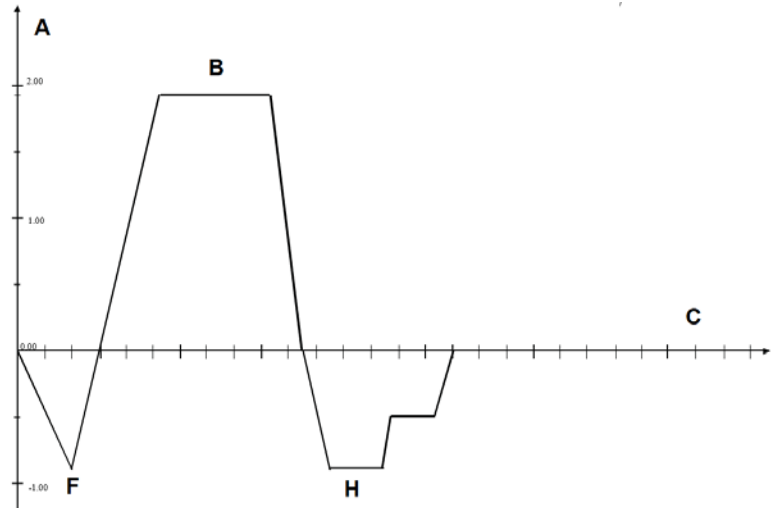

PROGRAM
S 132°C HOLLOW UNWRAPPED
132°C – 4 minutes

- A** PRESSURE (BAR)
- B** PROCESS
- C** TIME (MIN)
- J** FRACTIONATED PRE-VACUUM
- H** SHORT DRYING

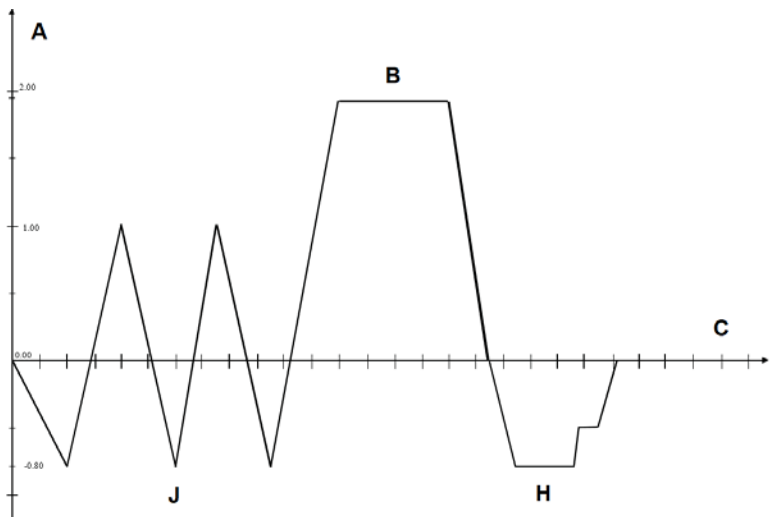

PROGRAM
B 132°C HOLLOW WRAPPED
132°C – 4 minutes

- A** PRESSURE (BAR)
- B** PROCESS
- C** TIME (MIN)
- D** FRACTIONATED VACUUM
- E** LONG DRYING

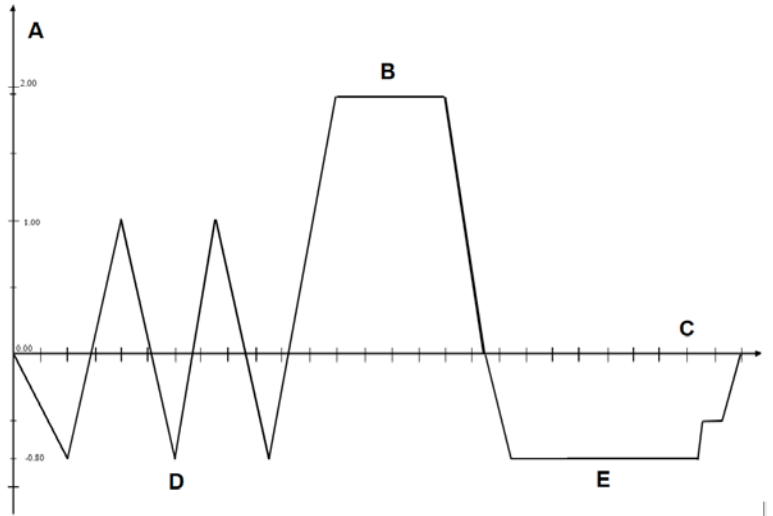

PROGRAM
B 121°C RUBBER & PLASTIC
121°C – 20 minutes

- A** PRESSURE (BAR)
- B** PROCESS
- C** TIME (MIN)
- F** FRACTIONATED PRE-VACUUM
- G** LONG DRYING

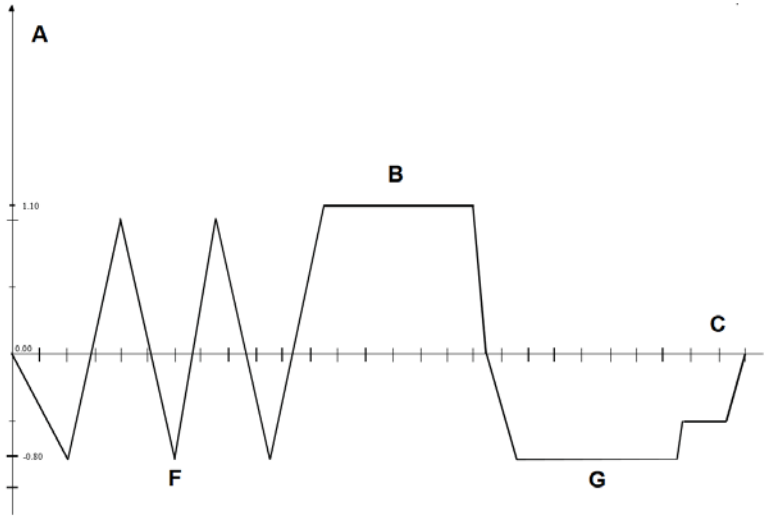

13.6 DIAGRAMS OF THE TEST PROGRAMMES

PROGRAM

B&D TEST

134°C – 3.5 minutes

- A** PRESSURE (BAR)
- B** PROCESS
- C** TIME (MIN)
- F** FRACTIONATED PRE-VACUUM
- H** SHORT DRYING

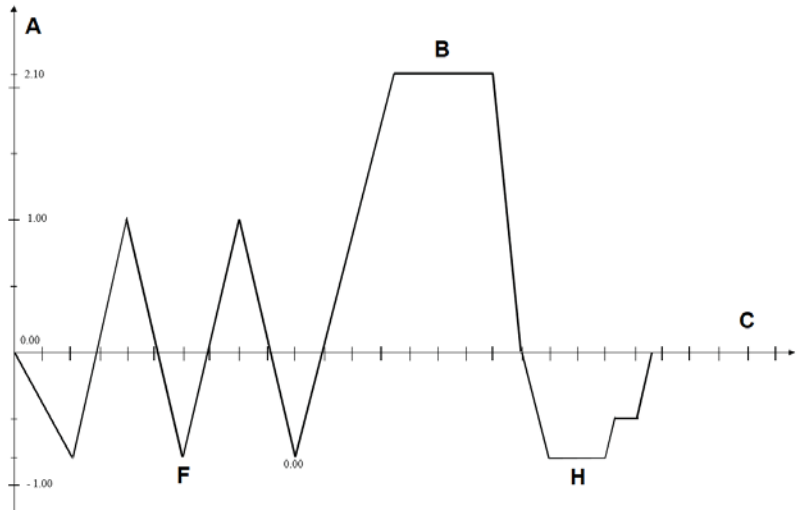

PROGRAM

VACUUM TEST

-0.80 bar

- A** PRESSURE (BAR)
- C** TIME (MIN)
- L** INTERMEDIATE CONDITION TO CONTINUE THE TEST
- M** FINAL CONDITION TO PASS THE TEST
- N** VACUUM PHASE
- O** STANDBY
- P** LOSS MEASUREMENT

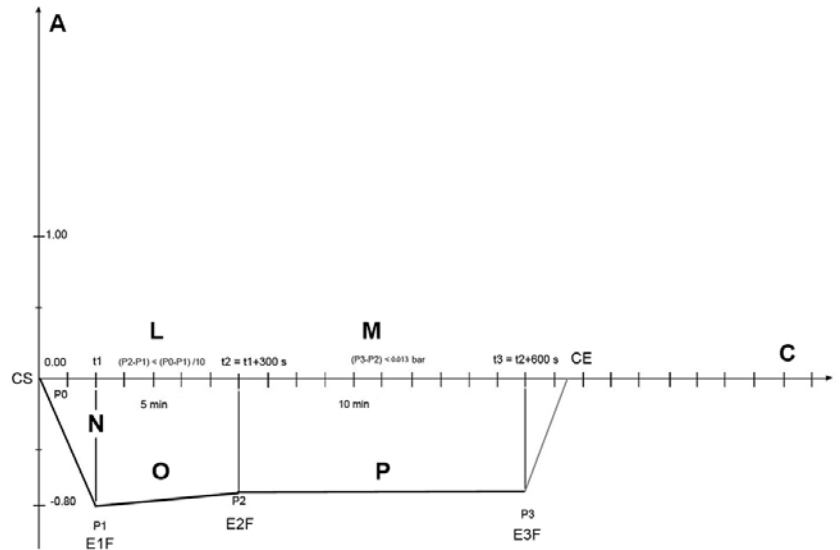

13.7 EXAMPLES OF PRINTED REPORTS

(WITH OPTIONAL PRINTER)

Program Printing (Standard)		Program Printing B&D Test		Program Printing Vacuum Test	
Machine model	Bravo G4 17	Machine model	Bravo G4 22	Machine model	Bravo G4 22
Serial Number	AJAPA184	Serial Number	AJBPA185	Serial Number	AJBPA185
FW Version	1.07/J001	FW Version	1.07/J001	FW Version	1.07/J001
Current cycle	00098	Current cycle	00084	Current cycle	00083
Cycle Counter	00091/00117	Cycle Counter	00069/00085	Cycle Counter	00069/00085
Program	132°C Solid W. S	Program	134°C B&D TEST	Program	Vacuum Test
Temperature	132 °C	Temperature	134 °C	CYCLE START	03/08/2020
Pressure	1.86 bar	Pressure	2.10 bar		10:10
Process time	4 min	Process time	3.5 min	OPERATOR:	-----
Standby	ON	Standby	ON	Time	°C bar
Prevacuum	SINGLE	Prevacuum	FRACTIONATED	-----	-----
Drying time	12.98 min	Drying time	1.10 min	00:00 CS	26.8 0.006
Measuring H2O	1.3 uS/cm	Measuring H2O	1.1 uS/cm	00:02 CSV	26.8 0.006
CYCLE START	28/07/2020	CYCLE START	03/08/2020	03:05 E1F	26.2 -0.803
	10:10		10:58	08:05 E2F	26.4 -0.802
OPERATOR:	-----	OPERATOR:	-----	18:05 E3F	26.4 -0.801
Time	°C bar	Time	°C bar	18:54 CE	28.9 0.003
-----	-----	-----	-----	-----	-----
00:00 CS	71.7 0.007	00:00 CS	26.5 0.007	CYCLE END	03/08/2020
01:04 CSV	70.0 0.007	13:59 CSV	55.0 0.006		10:29
05:52 3PV	72.3 -0.799	17:30 1PV	56.6 -0.797	VACUUM TEST:	PASS
13:32 ET	133.0 1.940	23:57 1FP	120.0 1.011	OPERATOR:	-----
13:47 SS	133.2 1.954	26:20 2PV	65.5 -0.804		
14:47	133.0 1.956	31:00 2FP	120.8 1.014		
15:47	133.2 1.958	33:22 3PV	82.2 -0.803		
16:47	133.2 1.960	42:11 ET	135.0 2.109		
17:47	133.2 1.959	42:26 SS	135.2 2.132		
17:47 SE	133.2 1.959	43:26	135.2 2.135		
19:19 DS	101.3 -0.002	44:26	135.2 2.135		
20:05 SPD	65.8 -0.808	45:26	135.3 2.135		
33:04 EPD	90.6 -0.602	45:56 SE	135.3 2.134		
34:20 CE	93.3 0.005	47:22 DS	101.4 -0.001		
-----	-----	48:18 SPD	85.7 -0.806		
14:07	MAX 133.3 °C	49:24 EPD	86.5 -0.596		
13:57	MIN 132.9 °C	50:24 DE	92.1 -0.121		
Drying pulse	17	50:46 CE	93.9 -0.000		
CYCLE END	28/07/2020	42:36	MAX 135.3 °C		
	10:44	42:46	MIN 135.1 °C		
CYCLE:	PASS	Drying pulse	2		
OPERATOR:	-----	CYCLE END	03/08/2020		
			11:48		
		CYCLE:	PASS		
		OPERATOR:	-----		

The text printed on the receipt remains for a couple of years, if correctly stored (away from any source of heat and in a cool, dry place). Store thermal receipts using cellulose envelopes, do not use plastic bags.

14. APPENDIX - MAINTENANCE

In addition to correct use, the user needs to perform regular maintenance in order to guarantee safe, efficient operation over the device's entire life.



Always use personal protective equipment.



For better quality of maintenance, supplement routine checks with regular periodic check-ups that can be performed by Technical Service Department (*see Appendix*).

It is also fundamental to perform a **periodic sterilizer validation**, i.e. a check of process thermo-dynamic parameters and their comparison with the reference values detected by duly calibrated tools. Refer to 'Sterilizer Periodic Validation' in the next part of the Appendix.

The regular maintenance described below consists in easy manual operations and preventative interventions involving simple tools.



In the event of replacement of components or parts of the device, request and/or use original spare parts only.

14.1 REGULAR MAINTENANCE PROGRAMME

The table summarizes the maintenance interventions required to maintain the sterilizer in good working order.

In case of **heavy use**, we recommend **shortening** maintenance intervals:

DAILY	Clean the door gasket and the internal part of the door (14.3.1)		
WEEKLY	Clean external surfaces (14.3.3) Clean the sterilization chamber and its accessories (14.3.2) Clean the anti-dust filter (14.3.6)		
MONTHLY	Clean the internal water tank (14.3.9)		
PERIODICALLY	Warnings related to Scheduled Maintenance are displayed with the following frequency (14.2):		
	WARNING MESSAGE	FREQUENCY	
	CHAMBER FILTER CLEANING (14.3.4)	250 CYCLES	or 3 MONTHS
	DOOR LOCK LUBRICATION (14.3.5)	250 CYCLES	or 3 MONTHS
	ANTI-DUST FILTER CLEANING (14.3.6)	500 CYCLES	or 6 MONTHS
	BACTERIOLOGICAL FILTER REPLACEMENT (14.3.7)	500 CYCLES	or 6 MONTHS
	DOOR GASKET REPLACEMENT (14.3.8)	1000 CYCLES	or 1 YEAR
	GENERAL SERVICE	3000 CYCLES	or 3 YEARS

A regular maintenance is essential to achieve the best performance of the device. Periodically, a message will be displayed requesting that the above maintenance operations are performed. For further information or in case of doubt, contact the Technical Service.

14.2 SCHEDULED MAINTENANCE MESSAGES

The sterilizer periodically displays warning messages relevant to “routine” maintenance operations that must be carried out in order to ensure the proper operation of the device.

Press DONE to confirm that the required maintenance operation has been completed.

Press REMIND button to postpone the operation.

In this case, the warning message will reappear the next time the sterilizer is used.

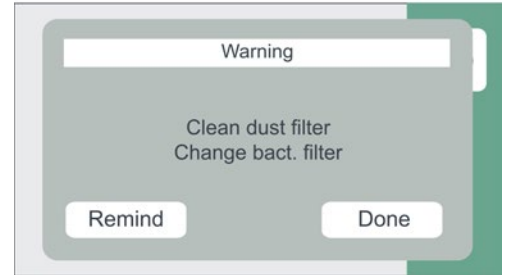

Always keep in mind the following **general warnings**:

- › **DO NOT** wash the sterilizer with direct **jets of water**, neither under pressure nor sprinkled. Seepage into electrical and electronic components could irreparably damage the functioning of the device or its internal parts.
- › **DO NOT** use **abrasive cloths, metal brushes** (or other aggressive materials) or **products for metal cleaning**, both solid and liquid, to clean the device and the sterilization chamber.
- › **DO NOT** use **unsuitable chemical products or disinfectants** to clean the sterilization chamber. In fact, these products can cause irreparable damage.
- › **DO NOT** allow **limescale or residues of other substances** to accumulate in the sterilization chamber, on the door and on the gasket, and remove these residues periodically. In fact, such residues may damage these parts, and compromise the operation of the hydraulic circuit components.

The formation of white spots on the base of the internal wall of the chamber means that you are using poor quality demineralized water.



Before performing regular maintenance, make sure that the power cord plug is removed from the mains socket.
If this is not possible, move the external switch of the device's power supply line to Off.
If the external switch is distant or not visible to the maintainer, place a “work in progress” sign on the switch, after turning it off.

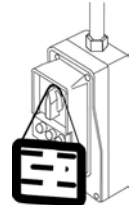

14.3 DESCRIPTION OF MAINTENANCE INTERVENTIONS

Let's now look at the various operations to be carried out.

DOOR GASKET AND THE INTERNAL PART OF THE DOOR CLEANING

To eliminate any traces of limescale, clean the gasket of the chamber and the door porthole with a clean cotton cloth soaked in a soft solution of water and vinegar (or a similar product, checking the contents on the label before using).

Dry the surfaces and remove any residues before using the device.

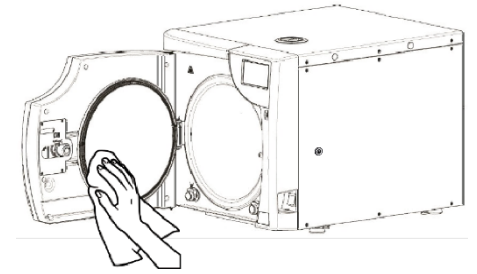

STERILIZATION CHAMBER AND ACCESSORIES CLEANING

Clean the sterilization chamber, support and trays (and internal surfaces in general) with a clean cotton cloth soaked in water and, possibly, the addition of a small amount of neutral detergent.

Carefully rinse with demineralized / distilled water, taking care not to leave any type of residue in the chamber or on accessories.

Do not use pointed or sharp tools to remove scale from the sterilization chamber. Should there be evident deposits, immediately check the quality of the demineralized / distilled water used (see Technical Characteristics Appendix).

EXTERNAL SURFACE CLEANING

Clean the external surfaces using appropriate product (i.e. Ethyl alcohol, 50% diluted with water).

Apply product with a soaked cloth, then dry.



Do not spray or vaporise any product directly on device surfaces.
Inflammable liquid.

CHAMBER FILTER CLEANING

With use it is likely that various residues accumulate in the filter and with time obstruct the lower drain duct.

To clean the filter, open the sterilizer door and remove the cap using a coin or another suitable tool.

Loosen the union that contains the filter.

Remove the filter from its support and thoroughly clean it under a jet of running water, if necessary using a sharp tool to remove any large foreign bodies (if possible use a jet of compressed air).

If it is impossible to recover the filter, replace it with a new one.

Refit everything operating in reverse order and making sure to screw the union in such a way that **the drain holes are positioned at the level of the boiler wall.**

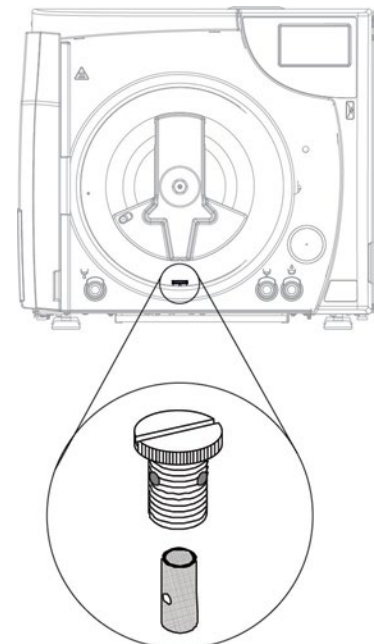

Properly fit the filter in its housing.
A partial fitting may damage the component.

DOOR LOCK LUBRICATION

Using a clean cloth, remove any residues from the bushing and the screw.

Lubricate the inside of the bushing on the sterilizer door with a film of the silicone-based grease provided (as shown in the figure).

Wear single-use gloves before application.

Essentially, the lubricant is not an irritant to the skin; nevertheless, it may cause unpleasant effects if it accidentally comes into contact with eyes.

In case of contact with eyes, rinse with plenty of water.

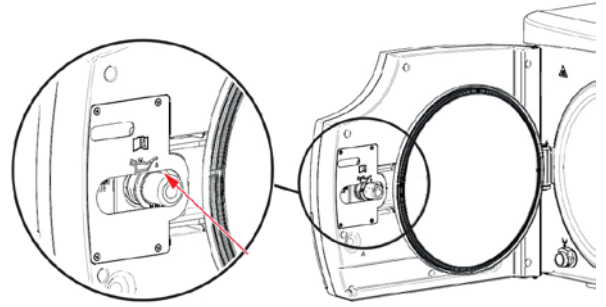

ANTI-DUST FILTER CLEANING

Remove the filter (A) from the lower part of the autoclave, thoroughly rinse it with water and dry it before refitting it.

The filter can be cleaned using a jet of compressed air, making sure not to disperse any dust into the environment.

REPLACE THE BACTERIOLOGICAL FILTER

When filter maintenance is due or every time you notice visible clogging of the filter (indicated by the filter markedly turning grey), unscrew the bacteriological filter (B) from its support and replace it with a new one, screwing it fully down on the union.

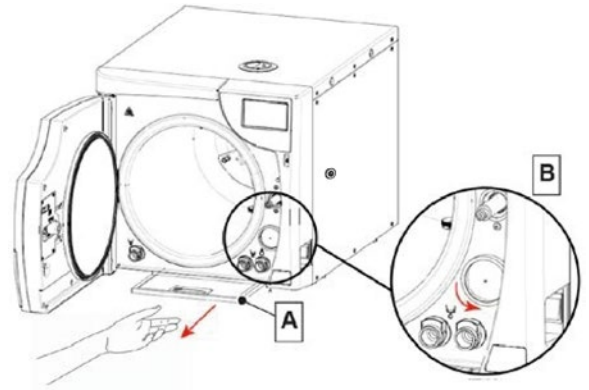

A spare bacteriological filter is provided with the device.

If you need spare parts of this component, refer to APPENDIX – TECHNICAL SERVICE.

DOOR GASKET REPLACEMENT

Before proceeding, open the door then switch off the device.

Remove the old gasket from the door by simply pulling it out by hand (no tools required). Clean the door gasket seat, to ensure it is debris-free.

Install the new door gasket by pressing it into its seat, starting from the top/bottom.

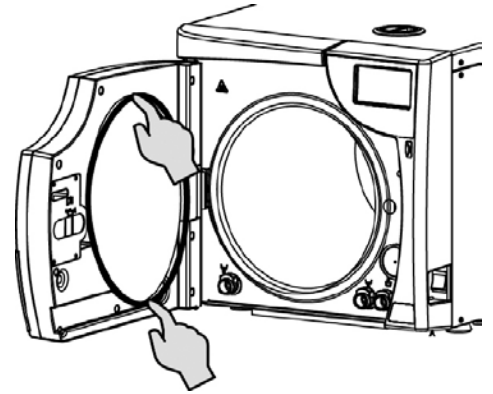

Then the sides.

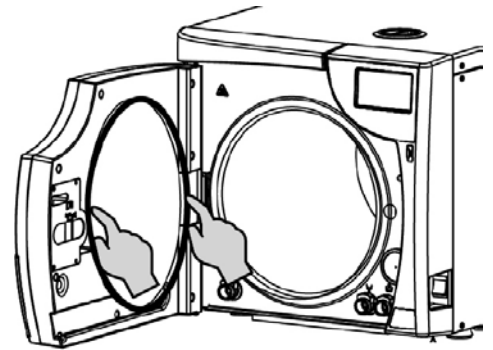

Finally press the remaining gasket sections completely into its seat. Do not lubricate the gasket nor the seat.

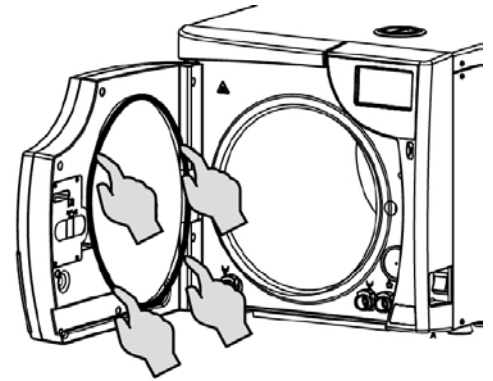

INTERNAL WATER RESERVOIR CLEANING

Do not run cycles during the following operations

Step 1

With the device ON, proceed to:

1. Open the door.
2. Arrange an empty container, with min. capacity of 5 L (1.32 gal).
3. Insert the manual drainage tubing with quick connector into the front port.
4. Fully drain the internal water reservoir by means of the front quick connector.

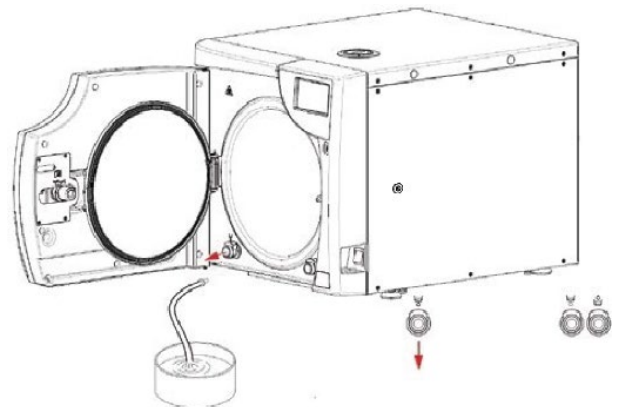

Step 2

Once the internal water reservoir is empty, disconnect the drainage tube from the quick connection port. Detaching the tube

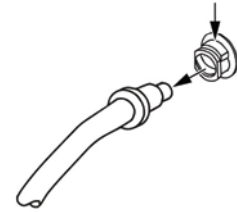

Step 3

1. Remove the cap from the top cover and manually fill with 70% ethyl alcohol + demineralized/distilled water solution (4 L / 1.05 gallon total, in equal parts).
2. Pour the 70% ethyl alcohol + demineralized/distilled water solution up to the MAX level, signalled by an audible warning.
3. Leave the solution to sit for 30 minutes.

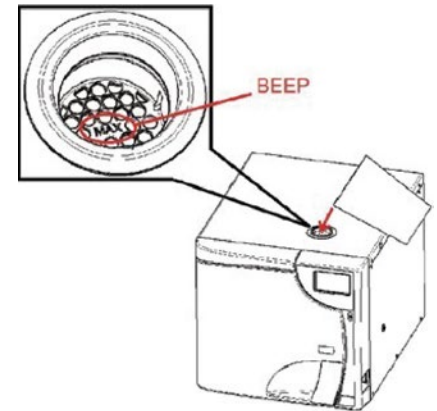

Step 4

Repeat STEP 1 to drain solution from the tank by means of the front quick connector.

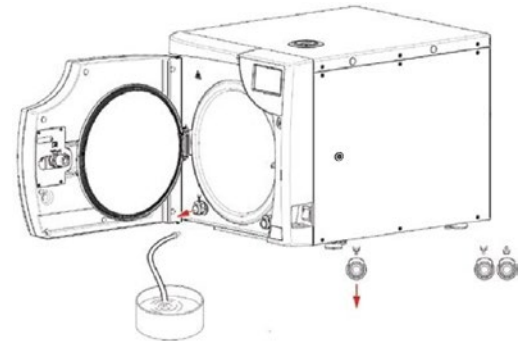

Step 5

Once the internal water reservoir is empty, disconnect the drainage tube from the quick connection port. Detaching the tube.

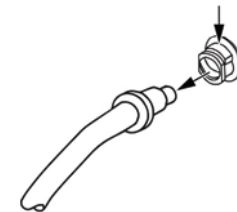

Step 6

1. Rinse the internal water reservoir with clean, demineralized/distilled water by again removing the cap from the top cover and manually filling up to the MAX level, signalled by an audible warning.
2. Leave the clean, demineralized/distilled water to sit for 5 minutes.

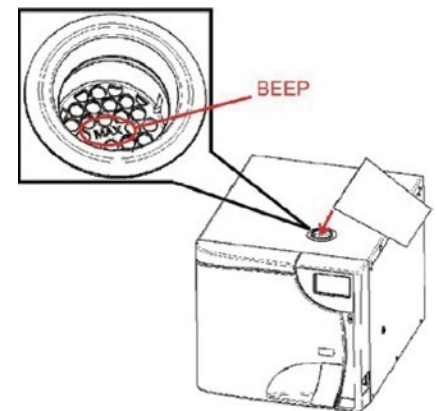

Step 7

1. Repeat STEP 1 to fully drain the internal water reservoir.
2. Once the reservoir has been rinsed and drained, it is important to fill the internal water reservoir with demineralized/distilled water before starting a cycle.
3. Resume normal operation of the unit, and fill the reservoir using one of the suitable manual or automatic fill options available.

14.4 PERIODIC STERILIZER VALIDATION

As happens with all devices, it is possible, and sometimes inevitable, to have a decrease in performance and the effectiveness of components along their lifespan, in a period of time dependent on its frequency of use.

To guarantee the safety of the process over time, it is periodically (depending on local guidelines or regulations) necessary to verify, the thermodynamic process parameters (pressure and temperature), to check if they continue to remain within allowed limits or not.

The requalification of the sterilizer's performance is the **responsibility of the user** of the product.

The reference standards ISO 17665-1 (Sterilization of health care products — Moist heat — Part 1: Requirements for the development, validation and routine control of a sterilization process for medical devices) is an effective guide for performing verifications on steam sterilizers.

Since, in addition to specific experience and training, these controls require the use of special equipment (high-precision sensors and probes, data loggers, dedicated software, etc.) suitably verified and calibrated, it is necessary to contact a **company specialized** in these activities.

Customer Service department (see Appendix) is available to provide any information relative to the periodic validation of steam sterilizers.

14.5 DEVICE USEFUL LIFE

Steam sterilizer service life is of 10 years (average use: 5 cycles/day, for 220 days/year). For normal use, it is expected that the device is used and maintained according to the instructions provided by the manufacturer.

The expected useful life of the device was determined according to a risk analysis carried out in compliance with requirements of standard ISO 14971.

14.6 DISPOSING THE EQUIPMENT WHEN NO LONGER USED

Concerning waste disposal, the unit must not be disposed of as municipal waste, but must be separated in accordance with **local provincial/state regulations**.

Appropriate differentiated waste collection for subsequent recycling treatment and environmentally friendly disposal contributes to preventing possible negative effects on the environment and health, and encourages recycling of the materials of which the device is made up. The symbol indicating separate collection for electrical and electronic equipment consists of the crossed out bin marked on the device.



Under national legislation, fines can be imposed if the product is disposed in an illegal manner.

15. APPENDIX - GENERAL PROBLEMS

If while using the device a problem or an alarm occurs, this **DOES NOT** mean that the device is out of order. It may not, in fact, be related to a breakdown but more probably to an anomalous situation, often merely transitory (such as a blackout), or incorrect use.

In any case, it is important to first identify the cause of the failure and then take suitable corrective actions, either autonomously or with the intervention of the **Technical Service Department** (*see Appendix*).

For this purpose, we provide instructions for diagnosing and resolving general problems, in addition to a precise description of the alarm codes, their meaning and their solution.

15.1 TROUBLESHOOTING

If your sterilizer is not working correctly, please make the following checks before contacting the Technical Service Department:

PROBLEM	POSSIBLE CAUSE	SUGGESTED SOLUTION
The sterilizer does not power-on.	The power cable is not plugged-in.	Plug it in.
	Lack of voltage at the power supply socket.	Check the cause of the lack of voltage at socket and fix it.
	The main switch and/or differential switch are turned to OFF.	Turn the switch to ON.
	The mains fuses are blown.	Contact Technical Service.
After pressing START, the sterilization cycle does not start.	The device is preheating.	Wait for the sterilizer to reach the proper operating conditions for starting the program. Under standard conditions, the Average Preheating Time is about 10-15 Minutes.
The safety valve has triggered.	Locking ring loosened. Presence of anomalous overpressure in the chamber.	Contact Technical Service.
Water presence on the sterilizer resting surface.	The automatic water filling system hose (optional) is not correctly connected.	Check the tightness of the fittings and, if necessary, reassemble them more carefully Check that the hoses are completely inserted on the fittings; check the presence of hose clamps..
	Steam leak from door gasket.	At the end of the cycle clean the gasket and the closing porthole with a dampened cloth. Check the presence of any gasket damage. Perform a new verification cycle.

TROUBLESHOOTING cont.

PROBLEM	POSSIBLE CAUSE	SUGGESTED SOLUTION
Excessive humidity on the material and/or instruments at the end of the program.	Excessive load in the sterilization chamber.	Check that the load does not exceed the maximum values allowed (See the Summary Table in Appendix "Technical Characteristics").
	Load not correctly positioned.	Position the load, in particular the wrapped one, as per the indications. (See Chapter "Preparing the material").
	Wrong selection of the sterilization program.	Choose the sterilization program suitable for the type of material to be treated. (See the Summary Table in "Programs" Appendix).
	Clogged chamber drain filter.	Clean or replace the chamber drain filter. (See Appendix "Maintenance").
Traces of oxidation or spots on instruments.	Quality of the instruments not adequate.	Check the quality of instruments, making sure that the material they are made of is suitable to tolerate the steam sterilization.
	Organic or inorganic residues on the instruments.	Carefully clean the material before subjecting it to the sterilization cycle. (See Chapter "Preparing the material").
	Contact between instruments made of different metals.	Separate instruments made of different metals. (See Chapter "Preparing the material").
	Presence of limescale residues on the wall of the chamber and/or accessories.	Clean the chamber and the accessories as prescribed. (See Appendix "Maintenance").
Blackening of the instruments or damage to the material.	Wrong selection of the sterilization program.	Choose the sterilization program suitable for the type of material to be treated. (See the Summary Table in "Programs" Appendix).

16. APPENDIX – ALARMS

If the problem persists, contact the Technical Service (see APPENDIX) communicating the sterilizer model and serial number. This data is indicated on the registration plate on the rear side of the device, on the declaration of conformity and can also be viewed by means of the “sterilizer information” command.

Every time an anomalous condition occurs during the operation of the sterilizer, an alarm is generated, identified by a specific code (consisting of a letter followed by a 3-digit number).

Alarm codes are divided into four categories:

	PROBLEM	SOLUTION	CODE FORMAT
E = ERROR/ WARNING	Incorrect handling and/or use or a cause outside the device.	The problem can normally be solved by the user.	Exxx (xxx = identification number 000 ÷ 999)
A = ALARM	First level fault	The problem can normally be solved on site by a specialized technician.	Axxx (xxx = identification number 000 ÷ 999)
H = HAZARD	Second level fault	The problem can normally be solved by the Technical Service Centre.	Hxxx (xxx = identification number 000 ÷ 999)
S = SYSTEM ERROR	Electronic system error (HW-FW).		Sxxx (xxx = identification number 000 ÷ 999)

In case of alarm, switch off the device only after having followed the indications displayed and having carried out the reset (see “Resetting the system” paragraph).

16.1 ALARM INTERVENTION

The alarm intervention causes the cycle interruption (or the normal operation interruption), the display of the relevant alarm code and message and an audible warning.

16.2 ALARM DURING A CYCLE

The alarm procedure is designed to ensure the user does not confuse an anomalous cycle with an efficiently carried out one, and therefore eliminate the unintentional use of unsterilized materials; it is structured to guide the user to RESET the sterilizer and follow the instructions below.

16.3 SYSTEM RESET

The system can be reset in two alternative ways, depending on the type of alarm (see the List of alarm codes below in this appendix):

- › Pressing the OK button
- › Following the instructions displayed and holding down the RESET button for about 3 seconds

Press the RESET button for approx. 3 seconds to go back to the main menu.

After the RESET and any technical operation necessary to eliminate the fault, the device will be ready to perform a new program.



Never turn off the device before carrying out the reset.



17. ALARM CODES

The list of alarm codes, the relevant messages displayed and RESET modes are indicated in the following table:

17.1 ERRORS (CATEGORY E)

The alarm codes in this list can refer to functions that are not present in the models concerned in this User Manual

CODE	ALARM DESCRIPTION	MESSAGE ON THE DISPLAY	RESET MODE
E000	Black-out	POWER OUTAGE CONTACT TECH. SERVICE	2
E001	Voltage of power supply line too high	OVERVOLTAGE CONTACT TECH. SERVICE	1
E002	Water conductivity threshold 1 exceeded	INSUFFICIENT H ₂ O QUALITY	1
E003	Water conductivity threshold 2 exceeded	QUALITY H ₂ O BAD CHANGE WATER	1
E004	Error in electrical mains frequency reading	LINE FREQ. ERROR CONTACT TECH. SERVICE	1
E007	One of the two fans is not working properly	FAN PROBLEM CONTACT TECH. SERVICE	1
E008	Water conductivity threshold 1 exceeded	FILTERS NEARLY EXHAUSTED	1
E009	Water conductivity threshold 2 exceeded	QUALITY H ₂ O BAD CHANGE WATER	1
E010	Door open	DOOR OPEN CLOSE DOOR	1
E020	Door lock system (closing) activation time-out exceeded	DOOR CLOSING ERROR CONTACT TECH. SERVICE	1 (then reattempt or turn off)
E021	Door lock system (opening) activation time-out exceeded	DOOR OPENING ERROR CONTACT TECH. SERVICE	1 (then reattempt or turn off)
E022	Door lock microswitches failure.	DOOR LOCK PROBLEM CONTACT TECH. SERVICE	2
E023	Door safety locking system failure.	DOOR LOCK PROBLEM CONTACT TECH. SERVICE	2
E030	The water in the feed tank is at minimum level (MIN.)	LOAD TANK MINIMUM LEVEL FILL TANK	1
E031	Maximum level of water in the drainage tank (MAX.)	DISCHARGE TANK MAXIMUM LEVEL EMPTY TANK	1
E042	The MAX. water level in the filling tank has been reached	LOAD TANK MAXIMUM LEVEL	1
E060	The autoclave cannot connect to LAN network	ETHERNET CONFIG. ERROR CHECK SETTINGS	1
E061	The autoclave cannot connect to WiFi network	WIFI CONFIG. ERROR CHECK SETTINGS	1
E126	Cloud firmware is being updated	CLOUD FW UPDATING WAIT	1

1 = OK (warning)

2 = OK + door unlocking + RESET (if in cycle)

ERRORS (CATEGORY E) cont.

CODE	ALARM DESCRIPTION	MESSAGE ON THE DISPLAY	RESET MODE
E141	The cloud firmware version is not the correct one with respect to the firmware process. There may be malfunctions in the connection with WiFi / ethernet or cloud	INCORRECT FW VERSION CLOUD UPDATE THIS FW	1
E900	Vacuum test failed (during TEST PHASE)	TEST FAILED SECOND STEP CONTACT TECH. SERVICE	2
E901	Vacuum test failed (during STAND-BY PHASE)	TEST FAILED FIRST STEP CONTACT TECH. SERVICE	2
E902	Vacuum test failed (vacuum pulse time-out exceeded)	TEST FAILED VACUUM NOT ACHIEVED CONTACT TECH. SERVICE	2
E998	Remote maintenance activity in progress	REMOTE SERVICE ACTIVE	1
E999	Manually interrupting the cycle	MANUAL INTERRUPTION	2

1 = OK (warning)

2 = OK + door unlocking + RESET (if in cycle)

17.2 ALARMS (CATEGORY A)

CODE	ALARM DESCRIPTION	MESSAGE ON THE DISPLAY	RESET MODE
A032	Problem with the level sensor of the filling tank	FILL. WATER LEVEL SENSOR PROBLEM CONTACT TECH. SERVICE	1
A040	The tank has not been filled (only with automatic filling system)	FAILED WATER INLET CHECK AUTOMATIC LOAD	1
A042	The MAX. water level in the filling tank has been reached abnormally (automatic filling)	WATER FILLING MAXIMUM LEVEL CHECK TANK	1
A101	Temperature sensor PT1 broken (sterilization chamber)	CHAMBER PROBE PT1 OPEN CIRCUIT CONTACT TECH. SERVICE	1
A102	Temperature sensor PT2 broken (steam generator)	GENERATOR PROBE PT2 OPEN CIRCUIT CONTACT TECH. SERVICE	1
A103	Temperature sensor PT3 broken (heating element)	HEATING BAND PROBE PT3 OPEN CIRCUIT CONTACT TECH. SERVICE	1
A105	Temperature sensor PT5 broken (conductivity measurement compensation)	CONDUCTIVITY SENSOR PT5 OPEN CIRCUIT CONTACT TECH. SERVICE	1
A111	Temperature sensor PT1 short-circuited (sterilization chamber)	CHAMBER PROBE PT1 SHORT-CIRCUIT CONTACT TECH. SERVICE	1
A112	Temperature sensor PT2 short-circuited (steam generator)	GENERATOR PROBE PT2 SHORT-CIRCUIT CONTACT TECH. SERVICE	1
A113	Temperature sensor PT3 short-circuited (heating element)	HEATING BAND PROBE PT3 SHORT-CIRCUIT CONTACT TECH. SERVICE	1
A115	Temperature sensor PT5 short-circuited (conductivity measurement compensation)	CONDUCTIVITY SENSOR PT5 SHORT-CIRCUIT CONTACT TECH. SERVICE	1
A116	ADC error	PROCESS BOARD ERROR CONTACT TECH. SERVICE	1
A117	Motor door overcurrent	MOTOR DOOR OVERCURRENT	2
A120	Reference heating element acquisition chain fault	PROCESS BOARD ERROR CONTACT TECH. SERVICE	1
A121	Reference heating element acquisition chain fault	PROCESS BOARD ERROR CONTACT TECH. SERVICE	1
A122	Reference heating element acquisition chain fault	PROCESS BOARD ERROR CONTACT TECH. SERVICE	1
A123	Solenoid valves control driver fault	EV DRIVER ERROR CONTACT TECH. SERVICE	2
A124	Door motor control driver fault	DOOR MOTOR DRIVER ERROR CONTACT TECH. SERVICE	2

1 = OK (warning)

2 = OK + door unlocking + RESET

ALARMS (CATEGORY A) (cont.)

CODE	ALARM DESCRIPTION	MESSAGE ON THE DISPLAY	RESET MODE
A125	Faulty current draw detected	FAULTY CURRENT DRAW CONTACT TECH. SERVICE	2
A126	Connection error with WiFi module	WiFi MODULE ERROR CONTACT TECH. SERVICE	1
A131	Solenoid valve 1 failed	SOLENOID VALVE 1 ERROR CONTACT TECH. SERVICE	2
A132	Solenoid valve 2 failed	SOLENOID VALVE 2 ERROR CONTACT TECH. SERVICE	2
A133	Solenoid valve 3 failed	SOLENOID VALVE 3 ERROR CONTACT TECH. SERVICE	2
A134	Solenoid valve 4 failed	SOLENOID VALVE 4 ERROR CONTACT TECH. SERVICE	
A135	Solenoid valve 5 failed	SOLENOID VALVE 5 ERROR CONTACT TECH. SERVICE	2
A136	Solenoid valve 6 failed	SOLENOID VALVE 6 ERROR CONTACT TECH. SERVICE	2
A137	Solenoid valve 7 failed	SOLENOID VALVE 7 ERROR CONTACT TECH. SERVICE	2
A140	Firmware update error	FW CLOUD UPDATE ERROR	1
A201	Pre-heating not executed within time-out (steam generator)	STEAM GENERATOR RESISTOR OPEN CIRCUIT CONTACT TECH. SERVICE	2
A202	Pre-heating not executed within time-out (tube bundle heating element)	HEATING BAND OPEN CIRCUIT CONTACT TECH. SERVICE	2
A250	1st pulse with vacuum not achieved within time out	1PV TIMEOUT CHECK LOAD CHECK CHAMBER FILTER	2
A251	1st rise back up to atmospheric pressure not reached within the time-out	ATM1 UPSTROKE TIMEOUT CONTACT TECH. SERVICE	2
A252	1st pressure pulse not reached within the time-out	1PP UPSTROKE TIMEOUT CONTACT TECH. SERVICE	2
A253	2nd pulse with vacuum not achieved within time out	2PV TIMEOUT CHECK LOAD CHECK CHAMBER FILTER	2
A254	2nd rise back up to atmospheric pressure not reached within the time-out	ATM2 UPSTROKE TIMEOUT CONTACT TECH. SERVICE	2
A255	2nd pressure pulse not reached within the time-out	2PP UPSTROKE TIMEOUT CONTACT TECH. SERVICE	2
A256	3rd pulse with vacuum not achieved within time-out	3PV TIMEOUT CHECK LOAD CHECK CHAMBER FILTER	2

1 = OK (warning)

2 = OK + door unlocking + RESET

ALARMS (CATEGORY A) (cont.)

CODE	ALARM DESCRIPTION	MESSAGE ON THE DISPLAY	RESET MODE
A257	3rd rise back up to atmospheric pressure not reached within the time-out	ATM3 UPSTROKE TIMEOUT CONTACT TECH. SERVICE	2
A258	3rd pressure pulse not reached within the time out	3PP UPSTROKE TIMEOUT CONTACT TECH. SERVICE	2
A260	Chamber depressurization not reached within time out	ATM3 DOWNSTROKE TIMEOUT CHECK LOAD CHECK CHAMBER FILTER	2
A261	Chamber levelling not reached within time out	PRESSURE LEVELLING TIMEOUT CONTACT TECH. SERVICE	2
A262	Vacuum pulsation during drying not executed within time-out	PD PRESSURE UPSTROKE TIMEOUT CONTACT TECH. SERVICE	2
A353	1st drop to atmospheric pressure not completed within the time-out	ATM1 DOWNSTROKE TIMEOUT CHECK LOAD CHECK CHAMBER FILTER	2
A356	2nd drop to atmospheric pressure not completed within the time-out	ATM2 DOWNSTROKE TIMEOUT CHECK LOAD CHECK CHAMBER FILTER	2
A360	Vacuum pulsation after maintenance step not executed within time-out	SPD PRESSURE DOWNSTROKE TIMEOUT CONTACT TECH. SERVICE	2
A362	Chamber depressurization during drying not reached within time-out	PD PRESSURE DOWNSTROKE TIMEOUT CONTACT TECH. SERVICE	2

1 = OK (warning)

2 = OK + door unlocking + RESET

17.3 HAZARDS (CATEGORY H)

CODE	ALARM DESCRIPTION	MESSAGE ON THE DISPLAY	RESET MODE
H150	MPX pressure sensor broken/not connected	PRESSURE SENSOR OPEN CIRCUIT CONTACT TECH. SERVICE	3
H160	MPX pressure sensor short-circuited	PRESSURE SENSOR SHORT-CIRCUIT CONTACT TECH. SERVICE	3
H400	Pconv/T ratio not balanced (Pconv>T) (STERILIZATION phase)	INCORRECT P/T RATIO CHECK LOAD	2
H401	T/Pconv ratio not balanced (T>Pconv) (STERILIZATION phase)	INCORRECT T/P RATIO CHECK LOAD	2
H402	Temperature over the MAX. limit (STERILIZATION phase)	TEMPERATURE BEYOND MAXIMUM LIMIT CONTACT TECH. SERVICE	2
H403	Temperature below the MIN. limit (STERILIZATION phase)	TEMPERATURE BELOW MINIMUM LIMIT CONTACT TECH. SERVICE	2
H404	Floating temperature over the limit (STERILIZATION phase)	ERRATIC TEMPERATURE CONTACT TECH. SERVICE	2
H405	Pressure over the MAX. limit (STERILIZATION phase)	PRESSURE BEYOND MAXIMUM LIMIT CONTACT TECH. SERVICE	2
H406	Pressure below MIN. limit (STERILIZATION phase)	PRESSURE BELOW MINIMUM LIMIT CONTACT TECH. SERVICE	2
H410	Time measurement error	INTERNAL TIMER ERROR CONTACT TECH. SERVICE	2
H411	Sterilization time error	STERILIZATION TIME ERROR	2
H990	Excessive pressure (sterilization chamber, MPX)	PRESSURE BEYOND MAXIMUM LIMIT CONTACT TECH. SERVICE	2
H991	Overheating (sterilization chamber, PT1)	PT1 OVERHEATING CHECK LOAD	2
H992	Overheating (steam generator, PT2)	PT2 OVERHEATING CONTACT TECH. SERVICE	2
H993	Overheating (layer resistance, PT3)	PT3 OVERHEATING CONTACT TECH. SERVICE	2

1 = OK (warning)

2 = OK + door unlocking + RESET

3 = Cycle failed + OK + door unlocking + RESET

17.4 SYSTEM ERRORS (CATEGORY S)

CODE	ALARM DESCRIPTION	MESSAGE ON THE DISPLAY	RESET MODE
S001	Flash memory 1 on process board failed	FLASH MEMORY NOT ACCESSIBLE CONTACT TECH. SERVICE	2
S002	Flash memory 2 on process board failed	FLASH MEMORY NOT ACCESSIBLE CONTACT TECH. SERVICE	2
S005	USB key not accessible	PROBLEM WITH USB KEY CHANGE KEY	2
S006	USB key not accessible	USB KEY NOT ACCESSIBLE CHANGE KEY	2
S007	USB key full	USB KEY FULL CHANGE KEY	2
S009	Printer not connected or incompatible printer	PRINTER DISCONNECTED CHECK CONNECTION	2
S010	Printer: there is no paper or there might be a configuration error	PRINTER PAPER OUT CHECK PAPER	2
S011	Printer cover open	PRINTER: DOOR OPEN	2
S012	Probable printer configuration error	PRINTER: NOT READY TRY AGAIN	2
S020	Cycle backup not done	RUN BACKUP DOWNLOAD NEW CYCLES	2
S021	Cycle storage limit exceeded	CYCLE MEMORY FULL START OVERWRITING	2
S030	Check, using a watchdog, that one of main tasks is not in crash condition	SYSTEM ERROR CONTACT TECH. SERVICE	2 (off-cycle) 3 (in cycle)
S031	Check, using a hardware watchdog, that one peripheral is not in lock condition.	SYSTEM ERROR CONTACT TECH. SERVICE	2 (off-cycle) 3 (in cycle)
S032	Check, using a watchdog, that one of main tasks is not in lock condition (e.g. infinite loop)	SYSTEM ERROR CONTACT TECH. SERVICE	2 (off-cycle) 3 (in cycle)
S034	SW malfunction	SYSTEM ERROR CONTACT TECH. SERVICE	2
S035	SW malfunction in solenoid valve management	SYSTEM ERROR CONTACT TECH. SERVICE	2
S040	Check the log saving in the Flash memory	SYSTEM ERROR CONTACT TECH. SERVICE	2 (off-cycle) 3 (in cycle)
S042	Cycle performed with standard drying	4-MINUTE STERILIZATION COMPLETED	1
S099	Error during cycle report creation	STANDARD DRYING CHECK LOAD DRYING	1
S100	SW malfunction	PROBLEM IN CREATING CYCLE REPORT CONTACT TECH. SERVICE	2

1 = OK (warning)

2 = OK + door unlocking + RESET

3 = Cycle failed + OK + door unlocking + RESET

17.5 TROUBLESHOOTING

According to the type of alarm occurred, please find below the indications to detect the possible causes and restore the proper operation.

ERRORS (CATEGORY E)

The alarm codes in this list can refer to functions that are not present in the models concerned in this User Manual

CODE	POSSIBLE CAUSE	SUGGESTED SOLUTION
E000	Sudden power failure (blackout).	Wait for the power to be restored and do a RESET following the instructions.
	The main switch has accidentally been turned off and/or the power plug pulled from the socket.	Reconnect the plug and/or turn the device on again and RESET according to the instructions.
	Network fuses blown.	Contact Technical Service.
E001	Abnormal voltage peak on the mains.	Reset according to the instructions. If the problem occurs again, have the mains electric system checked by a technician.
E002	The filling tank contains water of inadequate quality.	RESET according to the instructions. Empty the filling tank and refill it with demineralized / distilled water of adequate quality (<15µs/cm).
E003	The filling tank contains water of very poor quality.	RESET according to the instructions. IMMEDIATELY empty the filling tank and refill it with demineralized / distilled water of adequate quality (<15µs/cm).
		In these conditions, the sterilizer allows a maximum of 5 cycles, after which it locks until the tank is filled with demineralized / distilled water of adequate quality (<15 µs/cm). This precaution is necessary to prevent damage to the device.
E004	Failure to main board.	RESET according to the instructions. Contact Technical Service (see Appendix).
	Disturbance on the electrical mains.	RESET according to the instructions. If the problem occurs again, have the electrical mains checked by a technician. If the electrical mains are equipped with a Continuity system, have the system checked by a technician.
E007	One or more rear fans failed	RESET according to the instructions. Check the operation of rear fans and contact Technical Service (see Appendix).
E008	The filling/discharge tank contains water of inadequate quality.	RESET according to the instructions. Empty the filling tank and refill it with demineralized / distilled water of adequate quality (<15 µs/cm). If an automatic filling system is present, empty the external container and fill it with water of adequate quality.
E009	The filling/discharge tank contains water of very poor quality.	RESET according to the instructions. Empty the filling tank IMMEDIATELY and refill it with demineralized / distilled water of adequate quality (<15 µs/cm). If an automatic filling system is present, IMMEDIATELY empty the external container and fill it with water of adequate quality.
		In these conditions, the sterilizer allows a maximum of 5 consecutive cycles, after which it locks until the tank is filled with demineralized / distilled water of adequate quality (<15 µs/cm) are replaced. This precaution is necessary to prevent damage to the device.
E010	Door open (or not properly closed) at program start (START).	RESET according to the instructions. Properly close the door and restart the program.
	Door position microswitch failure.	Contact Technical Service (see Appendix).

TROUBLESHOOTING – ERRORS (CATEGORY E) cont.

CODE	POSSIBLE CAUSE	SUGGESTED SOLUTION
E020	Door lock mechanism limit microswitch failure.	RESET according to the instructions. Contact Technical Service (see Appendix).
	Door lock system gearmotor failure.	
E021	Door lock system lack of lubrication	RESET according to the instructions. Lubricate the door system
	Door lock mechanism limit microswitch failure.	RESET according to the instructions. Contact Technical Service (see Appendix).
E022	Door lock system gearmotor failure.	
	Door lock microswitches failure	RESET according to the instructions. Contact Technical Service (see Appendix).
E023	Door safety locking system failure.	RESET according to the instructions. Contact Technical Service (see Appendix).
E030	Water level in the filling tank below minimum.	RESET according to the instructions. Top up the water to the MAX. level (or at least over the MIN. level).
	MIN. water level sensor failure.	Contact Technical Service (see Appendix).
E031	Water level in the drain tank over the MAX. level.	RESET according to the instructions and empty the tank. Completely drain the drain tank.
	MAX. water level sensor failure.	Contact Technical Service (see Appendix).
E042	Warning that the maximum water level in the tank has been reached (manual filling)	Interrupt the filling operation to prevent water spillage.
E060	The autoclave cannot connect to LAN network	Make sure that configuration parameters of the Lan network are correct. Check that the Lan network chosen for the connection is working properly. Contact Technical Service (see Appendix).
E061	The autoclave cannot connect to WiFi network	Make sure that configuration parameters of the WiFi network are correct. Check that the router managing the WiFi network is on and that the WiFi network chosen for the connection is working properly. Contact Technical Service (see Appendix).
E126	Cloud firmware is being updated	Wait for the message to disappear and restart the machine
E141	The cloud firmware version is not the correct one with respect to the firmware process. There may be malfunctions in the connection with WiFi / ethernet or cloud	Contact Technical Service
E900	Air seepage through the gasket.	RESET according to the instructions. Thoroughly clean the gasket with a clean cotton cloth moistened with water. Restart the program.
	Problem in the hydraulic circuit.	Contact Technical Service (see Appendix).
E901	Excessive humidity in the sterilization chamber.	RESET according to the instructions. Thoroughly dry the inside of the chamber and restart the program.
	Air seepage through the gasket.	RESET according to the instructions. Thoroughly clean the gasket with a clean cotton cloth moistened with water.
	Problem in the hydraulic circuit.	Restart the program. Contact Technical Service (see Appendix).

TROUBLESHOOTING – ERRORS (CATEGORY E) cont.

CODE	POSSIBLE CAUSE	SUGGESTED SOLUTION
E902	Excessive humidity in the sterilization chamber.	RESET according to the instructions. Thoroughly dry the inside of the chamber and restart the program.
	Air seepage through the gasket.	RESET according to the instructions. Thoroughly clean the gasket with a clean cotton cloth moistened with water. Restart the program.
	Vacuum pump failure. Problem in the hydraulic circuit.	Contact Technical Service (see Appendix).
E998	Service maintenance in progress.	Service maintenance in progress. If you were not informed, contact IMMEDIATELY the manager of the network to which the sterilizer is connected. Contact Technical Service (see Appendix).
E999	Manual interruption of the sterilization or test cycle.	RESET according to the instructions.

TROUBLESHOOTING – ALARMS (CATEGORY A)

CODE	POSSIBLE CAUSE	SUGGESTED SOLUTION
A032	Connector of water level sensors in the filling tank not connected. Failure of water level sensor(s) in the filling tank.	Contact Technical Service (see Appendix).
A040	Lack of water in the external container (automatic filling)	RESET according to the instructions. Fill the container with a sufficient quantity of water (check the level at regular intervals).
	Automatic filling system not properly installed.	RESET according to the instructions. Check that the filling tube is properly connected. Remove any obstruction along the tube path.
	Automatic filling system failure.	Contact Technical Service (see Appendix).
A042	Possible problem to the Automatic filling system	Contact Technical Service (see Appendix).
A101	Chamber temperature sensor failure (PT1).	Contact Technical Service (see Appendix).
A102	Steam generator temperature sensor failure (PT2).	Contact Technical Service (see Appendix).
A103	Heating element temperature sensor failure (PT3).	Contact Technical Service (see Appendix).
A105	Temperature sensor PT5 failed (conductivity measurement compensation)	Contact Technical Service (see Appendix).
A111	Incorrect temperature sensor connection (sterilization chamber).	Contact Technical Service (see Appendix).
	Temperature sensor short-circuit (sterilization chamber).	
A112	Incorrect temperature sensor connection (steam generator).	Contact Technical Service (see Appendix).
	Temperature sensor short-circuit (steam generator).	

TROUBLESHOOTING – ALARMS (CATEGORY A) cont.

CODE	POSSIBLE CAUSE	SUGGESTED SOLUTION
A113	Incorrect temperature sensor connection (heating element).	Contact Technical Service (see Appendix).
	Temperature sensor short-circuit (heating element).	
A115	Temperature sensor PT5 short-circuited (conductivity measurement compensation).	Contact Technical Service (see Appendix).
A116	ADC error.	Contact Technical Service (see Appendix).
A117	Door lock system lack of lubrication	Lubricate the door system
A120	Reference heating element acquisition chain fault.	Contact Technical Service (see Appendix).
A121	Reference heating element acquisition chain fault.	Contact Technical Service (see Appendix).
A122	Reference heating element acquisition chain fault.	Contact Technical Service (see Appendix).
A123	Solenoid valves control driver fault	Contact Technical Service (see Appendix).
A124	Door motor control driver fault	Contact Technical Service (see Appendix).
A126	Connection error with WiFi module	Contact Technical Service (see Appendix).
A131	Solenoid valve 1 failed	Contact Technical Service (see Appendix).
A132	Solenoid valve 2 failed	Contact Technical Service (see Appendix).
A133	Solenoid valve 3 failed	Contact Technical Service (see Appendix).
A134	Solenoid valve 4 failed	Contact Technical Service (see Appendix).
A135	Solenoid valve 5 failed	Contact Technical Service (see Appendix).
A136	Solenoid valve 6 failed	Contact Technical Service (see Appendix).
A137	Solenoid valve 7 failed	Contact Technical Service (see Appendix).
A140	Firmware update error	Contact Technical Service (see Appendix).
A145	Faulty current draw detected	Contact Technical Service (see Appendix).
A201	Steam generator safety thermostat triggered.	Contact Technical Service (see Appendix).
	Steam generator or heating element malfunction.	
A202	Heating element safety thermostat triggered.	Contact Technical Service (see Appendix).
	Steam generator or heating element malfunction.	
A250	Water or condensate in the sterilization chamber.	RESET according to the instructions. Thoroughly dry the inside of the sterilization chamber and restart the cycle. DO NOT insert material impregnated with water or other liquids into the chamber.
	Drain filter obstructed.	Clean the chamber drain filter. (See Appendix Maintenance).
	Air seepage through the gasket.	RESET according to the instructions. Thoroughly clean the gasket with a clean cotton cloth moistened with water. Restart the cycle.
	Vacuum pump failure. Problem in the hydraulic circuit.	Contact Technical Service (see Appendix).

TROUBLESHOOTING – ALARMS (CATEGORY A) cont.

CODE	POSSIBLE CAUSE	SUGGESTED SOLUTION
A251	Water injection pump malfunction.	Contact Technical Service (see Appendix).
	Problem in the hydraulic circuit.	
	Steam generator safety thermostat triggered.	
A252	Steam seepage through the gasket.	RESET according to the instructions. Thoroughly clean the gasket with a clean cotton cloth moistened with water. Restart the cycle.
	Excessive load.	RESET according to the instructions. Check that the load does not exceed the maximum values permitted. (See the Summary Table in Appendix Technical Characteristics).
	Problem in the hydraulic circuit.	Contact Technical Service (see Appendix).
Steam generator safety thermostat triggered.		
A253	Steam generator malfunction.	RESET according to the instructions. Thoroughly dry the inside of the sterilization chamber and restart the program. Do not insert material impregnated with water or other liquids into the chamber.
	Water or condensate in the sterilization chamber.	
	Air seepage through the gasket.	
A254	Vacuum pump failure.	Contact Technical Service (see Appendix).
	Problem in the hydraulic circuit.	
	Water injection pump malfunction.	
A255	Problem in the hydraulic circuit.	Contact Technical Service (see Appendix).
	Steam generator safety thermostat triggered.	
	Steam generator malfunction.	
A255	Steam seepage through the gasket.	RESET according to the instructions. Thoroughly clean the gasket with a clean cotton cloth moistened with water. Restart the program.
	Excessive load.	RESET according to the instructions. Check that the load does not exceed the maximum values permitted. (See the Summary Table in Appendix Technical Characteristics).
	Problem in the hydraulic circuit.	Contact Technical Service (see Appendix).
Steam generator safety thermostat triggered.		
A255	Steam generator malfunction.	Contact Technical Service (see Appendix).
	Steam generator safety thermostat triggered.	

TROUBLESHOOTING – ALARMS (CATEGORY A) cont.

CODE	POSSIBLE CAUSE	SUGGESTED SOLUTION
A256	Water or condensate in the sterilization chamber.	RESET according to the instructions. Thoroughly dry the inside of the sterilization chamber and restart the program. DO NOT insert material impregnated with water or other liquids into the chamber.
	Air seepage through the gasket.	RESET according to the instructions. Thoroughly clean the gasket with a clean cotton cloth moistened with water. Restart the program.
	Vacuum pump failure. Problem in the hydraulic circuit.	Contact Technical Service (see Appendix).
A257	Water injection pump malfunction. Problem in the hydraulic circuit.	Contact Technical Service (see Appendix).
	Steam generator safety thermostat triggered.	Contact Technical Service (see Appendix).
	Steam generator malfunction.	Contact Technical Service (see Appendix).
A258	Steam seepage through the gasket.	RESET according to the instructions. Thoroughly clean the gasket with a clean cotton cloth moistened with water and restart the program.
	Excessive load.	RESET according to the instructions. Check that the load does not exceed the maximum values permitted. (See the Summary Table in Appendix Technical Characteristics).
	Problem in the hydraulic circuit. Steam generator safety thermostat triggered.	Contact Technical Service (see Appendix).
	Steam generator malfunction.	Contact Technical Service (see Appendix).
A260	Drain filter obstructed.	Clean the chamber drain filter (see Maintenance Appendix).
	Problem in the hydraulic circuit.	Contact Technical Service (see Appendix).
A261	Drain filter obstructed.	Clean the chamber drain filter (see Maintenance Appendix).
	Problem in the hydraulic circuit.	Contact Technical Service (see Appendix).
A262	Drain filter obstructed.	Clean the chamber drain filter (see Maintenance Appendix).
	Problem in the hydraulic circuit.	Contact Technical Service (see Appendix).
A353	Drain filter obstructed.	Clean the chamber drain filter (see Maintenance Appendix).
	Problem in the hydraulic circuit.	Contact Technical Service (see Appendix).
A356	Drain filter obstructed.	Clean the chamber drain filter (see Maintenance Appendix).
	Problem in the hydraulic circuit.	Contact Technical Service (see Appendix).
A360	Drain filter obstructed.	Clean the chamber drain filter (see Maintenance Appendix).
	Problem in the hydraulic circuit.	Contact Technical Service (see Appendix).
A362	Drain filter obstructed.	Clean the chamber drain filter (see Maintenance Appendix).
	Problem in the hydraulic circuit.	Contact Technical Service (see Appendix).

TROUBLESHOOTING – HAZARDS (CATEGORY H)

CODE	POSSIBLE CAUSE	SUGGESTED SOLUTION
H150	Pressure sensor failure (MPX).	Contact Technical Service (see Appendix).
H160	Pressure sensor (MPX) not properly connected to the connector.	Contact Technical Service (see Appendix).
	Pressure sensor short-circuit (MPX).	
H400	Problem in the hydraulic circuit.	Contact Technical Service (see Appendix).
H401	Problem in the hydraulic circuit.	Contact Technical Service (see Appendix).
H402	Steam generator malfunction.	Contact Technical Service (see Appendix).
	Problem in the hydraulic circuit.	
H403	Steam generator malfunction.	Contact Technical Service (see Appendix).
	Problem in the hydraulic circuit.	
H404	Problem in the hydraulic circuit.	Contact Technical Service (see Appendix).
	Steam generator malfunction.	
H405	Problem in the hydraulic circuit.	Contact Technical Service (see Appendix).
	Steam generator malfunction.	
H406	Problem in the hydraulic circuit.	Contact Technical Service (see Appendix).
	Steam generator malfunction.	
H410	Timer problem.	Contact Technical Service (see Appendix).
H411	Sterilization time error	Contact Technical Service (see Appendix).
H990	General operating problem.	Contact Technical Service (see Appendix).
H991	General operating problem.	Contact Technical Service (see Appendix).
H992	General operating problem.	Contact Technical Service (see Appendix).
H993	General operating problem.	Contact Technical Service (see Appendix).

TROUBLESHOOTING – SYSTEM ERRORS (CATEGORY S)

CODE	POSSIBLE CAUSE	SUGGESTED SOLUTION
S001	Error of Flash memory 1 on process board	Contact Technical Service (see Appendix).
	Flash memory 1 on process board failed	
S002	Error of Flash memory 2 on process board	Contact Technical Service (see Appendix).
	Flash memory 2 on process board failed	
S005	USB key not correctly formatted	Check USB key correct formatting (FAT32). As an alternative, use another correctly formatted USB key. If the problem persists, contact Technical Service (see Appendix).
	Damaged USB key	
S006	USB key not correctly formatted	Check USB key correct formatting (FAT32). As an alternative, use another correctly formatted USB key. If the problem persists, contact Technical Service (see Appendix).
	Damaged USB key	
S007	USB key full	Download data from USB key or use another USB key. If the problem persists, contact Technical Service (see Appendix).

TROUBLESHOOTING – SYSTEM ERRORS (CATEGORY S) cont.

CODE	POSSIBLE CAUSE	SUGGESTED SOLUTION
S009	Printer off. Data cable not correctly connected to serial ports RS-232.	Make sure that printer is on. Check correct connection of the printer cable. Check printer compatibility. If the problem persists, contact Technical Service (see Appendix).
S010	No paper inside printer. Paper setting configuration not correctly done.	Make sure that paper is correctly loaded. Check correct connection of the printer cable. Make sure that paper settings are correct. If the problem persists, contact Technical Service (see Appendix).
S011	Printer lid open	Make sure that printer lid is correctly closed. Check correct connection of the printer cable. If the problem persists, contact Technical Service (see Appendix).
S012	Printer not ready for use	Make sure that paper is correctly loaded. Check correct connection of the printer cable. Make sure that paper settings are correct. If the problem persists, contact Technical Service (see Appendix).
S020	Cycle back-up not done after 250 cycles	Perform cycle back-up. See paragraph Sterilization cycle back-up. If the problem persists, contact Technical Service (see Appendix).
S021	Cycle storage limit exceeded after 7000 cycles	Perform cycle back-up. See paragraph Sterilization cycle back-up. If the problem persists, contact Technical Service (see Appendix).
S030	Malfunction of the control software	RESET according to the instructions. Try restarting the program a second time. If the problem persists, contact Technical Service (see the Appendix).
S031	Malfunction of control board or software	RESET according to the instructions. Try restarting the program a second time. If the problem persists, contact Technical Service (see the Appendix).
S032	Malfunction of the control software	RESET according to the instructions. Try restarting the program a second time. If the problem persists, contact Technical Service (see the Appendix).
S034	Malfunction of the control software	RESET according to the instructions. Try restarting the program a second time. If the problem persists, contact Technical Service (see the Appendix).
S035	Control software malfunction in solenoid valve management	RESET according to the instructions. Try restarting the program a second time. If the problem persists, contact Technical Service (see the Appendix).
S040	Malfunction of the control software	RESET according to the instructions. Try restarting the program a second time. If the problem persists, contact Technical Service (see the Appendix).
S041	Malfunction of control board or control software	Contact Technical Service (see Appendix).
S042	Malfunction of control board or software	Contact Technical Service (see Appendix).
S099	Malfunction of control board or control software	Try restarting the program a second time. Try replacing the USB key. If the problem persists, contact Technical Service (see the Appendix).
S100	Malfunction of control board or control software	Contact Technical Service (see Appendix).

18. USER PIN RESET

If the user enters the pin incorrectly for 3 times, it is necessary to enter the following unlock pin on the fourth consecutive time when you are prompted to enter pin again: **9999**

19. MANUAL DOOR OPENING

In case of power supply outage or if an unexpected event stops device operations, with consequent locking of the door, it's possible to proceed with the **MANUAL DOOR OPENING** operation described below.

Be careful to follow all the described steps.

The load removed from the sterilizer chamber after a manual door opening **MUST BE** considered as NON-STERILE, and consequently not suitable for the use.

Switch OFF the device, by means of the main power supply switch.

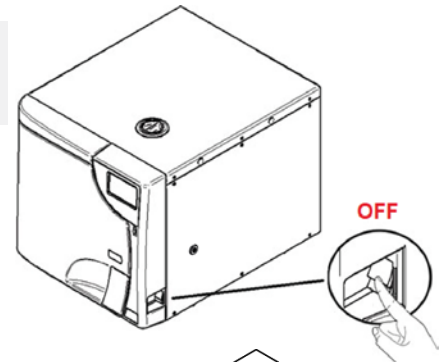

Using the 5mm Allen key (included with BRAVO G4 standard equipment) unlock the door safety locking system as following:

1. Insert the 5mm Allen key on the hexagonal groove, located on the right-side cover.

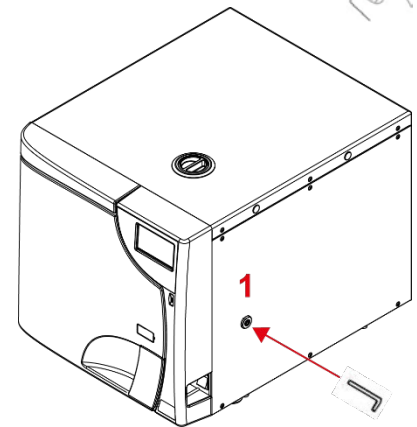

2. Push and rotate clockwise half turn, securing the system in unlocked position.

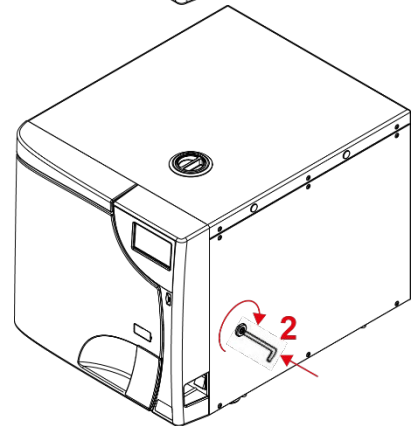

3. Remove the 5mm Allen key from the groove.

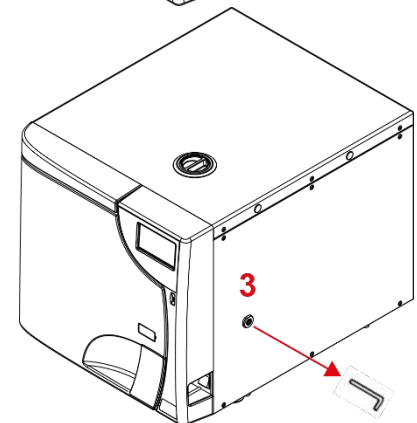

Remove the plastic cap from the front door cover, forcing slightly on the groove. Cap removal allows access to the worm shaft, part of the door locking system.

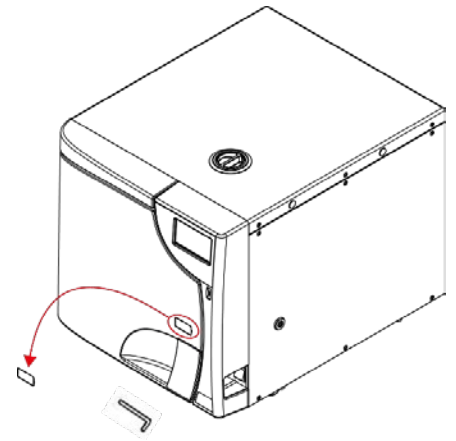

Using the 5mm Allen key (included with BRAVO G4 standard equipment) release the door locking system as following:

1. Insert the 5mm Allen key on the hexagonal seat, at the head of the worm shaft.
2. Rotate clockwise until releasing the door locking system.

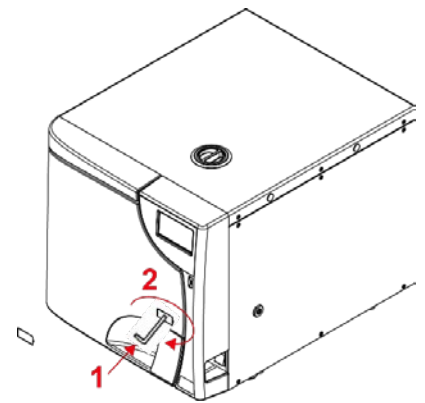

3. Open the door and remove the load.

NOTE: The load MUST BE considered as NON-STERILE.

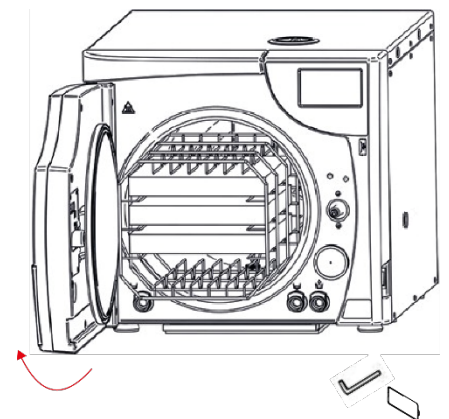

Using the 5mm Allen key (included with BRAVO G4 standard equipment) lock again the door safety locking system as follows:

1. Insert the 5mm Allen key on the hexagonal groove, located on the right-side cover.
2. Rotate counter-clockwise half turn, bringing the system back into a locked position.
3. Remove the 5mm Allen key from the groove.

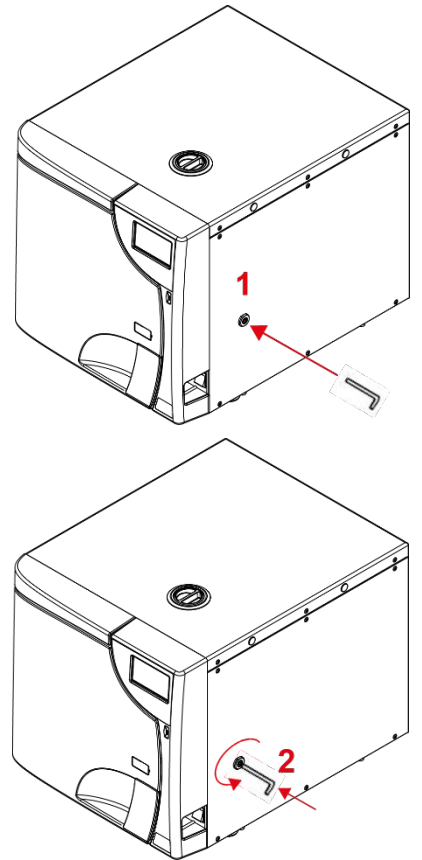

20. APPENDIX - ACCESSORIES



Only use spare parts and accessories that meet the manufacturer's specifications.

AUTOMATIC FILLING KIT



FRONT FILLING KIT

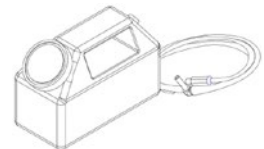

H2O AUX EV kit (AUX SV)

Auxiliary solenoid valve kit including:

- › 2 way water solenoid valve, NC - 24 V DC
- › Steel support and fastening screws
- › Connection cable with plug
- › Silicone hose with connector
- › Control valve
- › 1-way valve

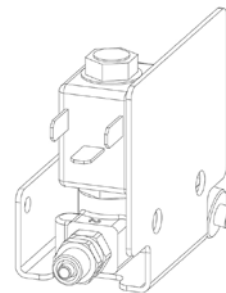

For the management of automatic filling accessories, refer to the manual of the relevant accessory.

EXTERNAL PRINTER



21. PRINTER CONNECTION

Connect the printer to the RS232 serial port located on the rear of the autoclave (see figure).

Load the desired type of paper and turn on the printer.

Set the type of paper loaded (see the paragraph PRINT MANAGEMENT).

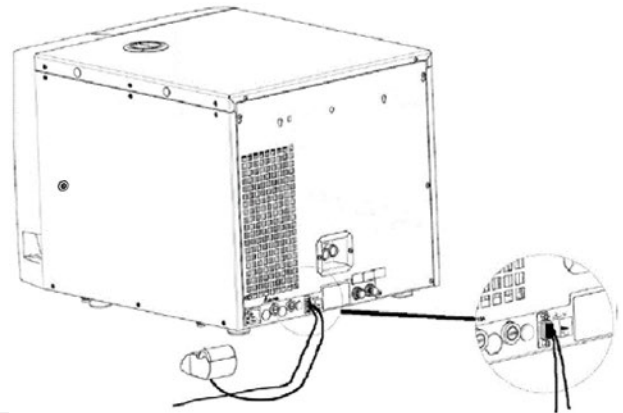

Only the optional external printer Ref. M7D200012 is compatible with the BRAVO G4.
Refer to the printer manual for printer starting and paper loading.

22. APPENDIX - SPARE PARTS AND ACCESSORIES

Only use spare parts and accessories that meet the manufacturer's specifications.

DESCRIPTION	CODE
Bacteriological Filter	97290160
Door Gasket (17/22 L)	97400145
Chamber Drain Filter	97290210

23. APPENDIX - TECHNICAL SERVICE

FOR ANY REQUEST FOR TECHNICAL INTERVENTION ON THE PRODUCT, BOTH UNDER WARRANTY AND OUT OF WARRANTY, DIRECTLY CONTACT THE DEALER OR RESELLER THAT SUPPLIED THE AUTOCLAVE.

We will gladly provide any information you may need on the product as well as give you suggestions and advice on the steam sterilization procedures.

In this regard, please refer to the following address:

Head Office:

SciCan Ltd.
1440 Don Mills Rd. Toronto, ON, Canada, M3B 3P9
T +1 416 445 1600
TF +1 800 667 7733
customerservice@scican.com
www.scican.com

24. APPENDIX - WARNINGS AND LOCAL REGULATIONS



Before carrying out any technical service operations, consult the Technical Service Manual containing the above instructions.